

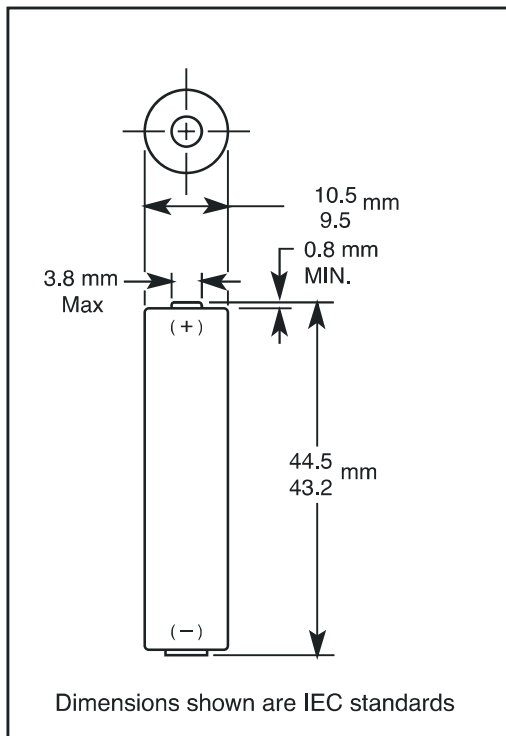

| | |
|-------------------------------------|---|
| Nominal Voltage: | 1.5 V |
| Operating Voltage | 1.6 - 0.75V |
| Impedance: | 250 m-ohm @ 1kHz |
| Typical Weight: | 11 gm (0.4 oz.) |
| Typical Volume: | 3.5 cm ³ (0.2 in. ³) |
| Terminals: | Flat |
| Storage Temperature Range: | -20°C to 35°C |
| Operating Temperature Range: | -20°C to 54°C (-4°F to 130°F) |
| ANSI: | 24A |
| IEC: | LR03 |

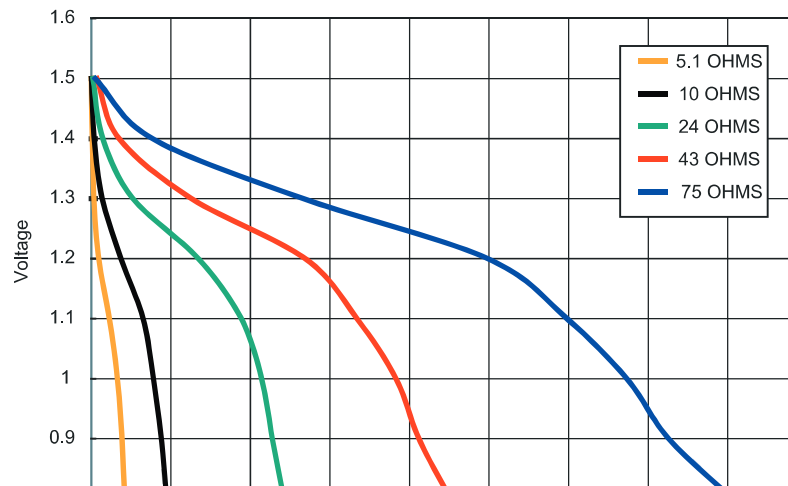

TYPICAL DISCHARGE CHARACTERISTICS AT 21°C (70°F)



TYPICAL CONSTANT CURRENT DISCHARGE CHARACTERISTICS AT 21°C (70°F)

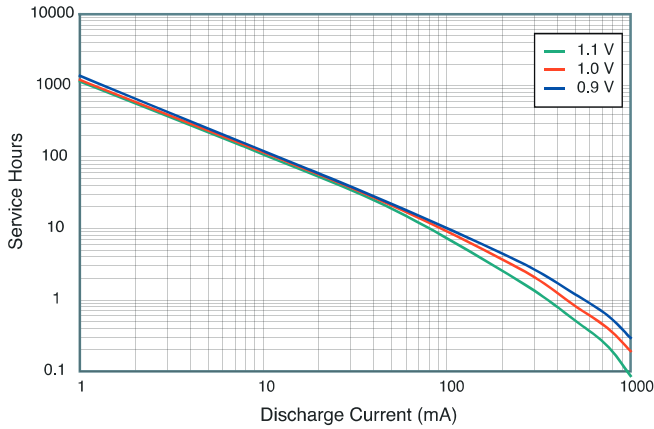

TYPICAL DISCHARGE CHARACTERISTICS AT 21°C (70°F)

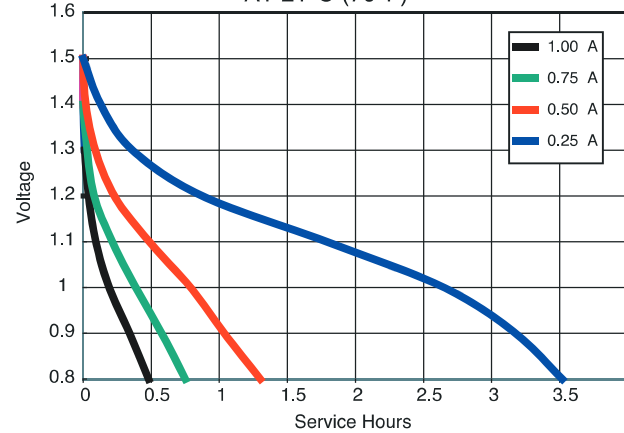

TYPICAL DISCHARGE CHARACTERISTICS AT 21°C (70°F)

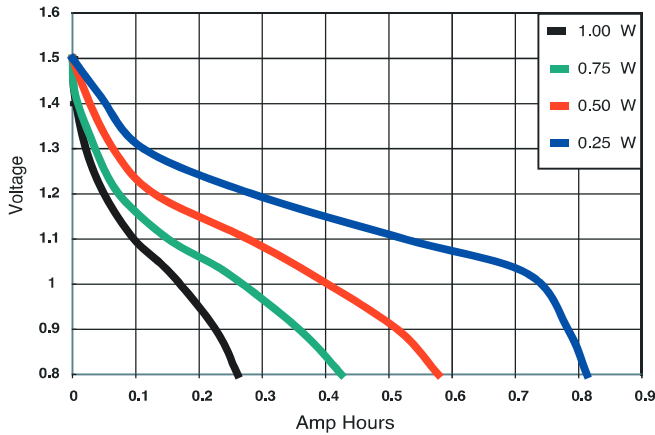

TYPICAL DISCHARGE PERFORMANCE AT 21°C (70°F)

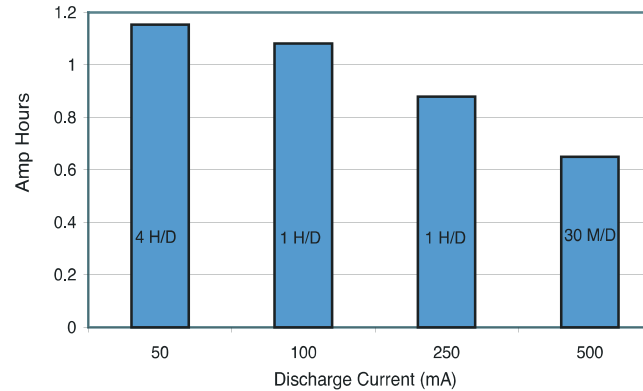

TYPICAL DC RESISTANCE CHARACTERISTICS AT 21°C (70°F)

