

### DS7 Soft Start Controllers



### Contents

<i>Description</i>	<i>Page</i>
DS7 Soft Start Controllers	
Features and Benefits	V6-T1-5
Standards and Certifications	V6-T1-5
Instructional Leaflets	V6-T1-5
Catalog Number Selection	V6-T1-6
Product Selection	V6-T1-7
Accessories	V6-T1-15
Technical Data and Specifications	V6-T1-16
Dimensions	V6-T1-24
Type S701, Soft Start Controllers	V6-T1-26
Type S701, Soft Start Controllers with Auxiliary Contact	V6-T1-32
Type S701, Soft Start Controllers with Brake	V6-T1-35
Type S511, Semiconductor Reversing Contactors	V6-T1-38

## DS7 Soft Start Controllers

### Product Description

The DS7 is available in standard and SmartWire-DT® communications configurations.

#### Standard (Non SmartWire-DT)

Eaton's DS7 line of reduced voltage solid-state soft start controllers is very compact, multi-functional, easy to install and easy to commission. Designed to control the acceleration and deceleration of three-phase motors, the device is available for current ranges from 4 to 200 FLA in four frame sizes. It is available with 24 Vdc, 24 Vdc/24 Vac, or 110/230 Vac control voltage options. A low temperature version is available with 24 Vac/Vdc control voltage with operation ambient temperature minimum of -40 °C.

#### SmartWire-DT

Our SmartWire-DT interface completely eliminates the need for conventional control wiring. This has several advantages:

- No incorrect wiring
- Faster wiring
- Cost saving

The interface can be used to send control commands to the DS7 SmartWire-DT and change and diagnose its parameter configuration; in addition, the control electronics can be powered via the SmartWire-DT cable. The device is controlled with one of the selectable profiles:

- A "start/stop" profile
- An 8 bit-wide profile for the soft starter, which is provided the same way for the variable frequency drive and features more options

Regardless of the profile chosen, the DS7 SmartWire-DT's parameters can be read and written to at any time by using acyclic communications services.

DS7 SmartWire-DT makes it possible to read and write to all device parameters. It is also possible to overwrite the potentiometer settings on the DS7 SmartWire-DT, which can come in handy, for instance, when a change made to the machine needs to be performed remotely.

The DS7 SmartWire-DT comes with a detailed diagnostic system with options that extend far beyond those of wired devices. In addition to having an error log, the DS7 SmartWire-DT can detect and report nine different device faults. A warning parameter reports any present warning messages. Moreover, the response to each individual fault can be customized. Finally, there are 35 additional messages for communication errors. Using the DS7 SmartWire-DT in connection with the PKE series motor protective circuit breakers opens up new functionalities that were previously thought impossible to implement with a low-cost soft starter and that were reserved to significantly more expensive devices. Combining a PKE unit and a DS7 SmartWire-DT makes it possible to completely protect the DS7 SmartWire-DT device against overloads. In addition, it provides a current limiting function and can report thermal capacity utilization levels to higher level controllers.

## Application Description

With its small size, it can easily fit in place of existing soft starters, wye-delta starters, or across-the-line NEMA® and IEC starters. This feature allows easy upgrades to existing systems. The product is designed to be wired in the three-phase line feeding the three motor input leads as is done for normal across-the-line starting. The starter uses silicon controlled rectifiers (SCRs) to ramp the voltage to the motor, providing smooth acceleration and deceleration of the load. After the motor is started, the internal run bypass relay closes, resulting in the motor running directly across-the-line. Internal run bypass significantly reduces the heat generated as compared to non-bypass starters. The soft stop option allows for a ramp stop time that may be longer than the coast-to-stop time. An external overload protection relay or circuit breaker is needed.

## Operation

### Voltage Ramp Start

This start method provides a voltage ramp to the motor, resulting in a constant torque increase. This most commonly used form of soft start mode allows you to set the initial voltage value and the duration of the ramp to full voltage conditions.

- Adjustable initial voltage 30–92% of full voltage (120/230 Vac control voltage)
- Adjustable initial voltage 30–100% of full voltage (24 Vac/Vdc control voltage)
- Adjustable initial voltage 30–92% of full voltage (24 Vdc control voltage—SmartWire-DT)
- Adjustable ramp time 1–30 seconds
- Bypass relays close at the end the ramp time (TOR)

### Soft Stop

Allows for a controlled stopping of load. Used when a stop-time that is greater than the coast-to-stop time is desired. Often used with high friction loads where a sudden stop may cause system or product damage. Setting the soft stop time to a value of 0 turns off this feature.

- Soft stop time = 0–30 seconds

### Start Ramp

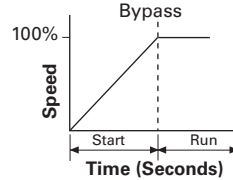

### Stop Ramp

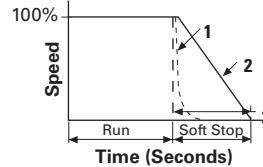

- 1 = Coast to Stop (Speed)
- 2 = Soft Stop Ramp (Voltage)
- 3 = Soft Stop Time

### Auxiliary Contacts

Auxiliary contacts are provided to indicate soft start controller status.

### Frame Size 1 (4A to 12A) — One Relay

The auxiliary relay indicates when the soft starter is at Top-of-Ramp (TOR).

### Frame Size 2, 3 and 4 (16A to 200A) — Two Relays

One auxiliary relay indicates when the soft starter is at Top-of-Ramp (TOR).

One auxiliary relay indicates that a RUN command is present, including start ramp, bypass, and stop ramp times.

### Features and Benefits

- Run bypass mode greatly reduces internal heating created by the power dissipation across the SCRs. The bypass relay directly connects the motor to the line and improves system efficiency by reducing internal power losses
- Less heat minimizes enclosure size and cooling requirements, and maximizes the life of all devices in the enclosure
- LED displays device status and provides fault indication
- Variable ramp times and voltage control (torque control) settings provide unlimited starting configurations, allowing for maximum application flexibility
- Soft stop control suits applications where an abrupt stop of the load is not acceptable. Soft acceleration and deceleration reduces wear on belts, gears, chains, clutches, shafts, and bearings
- Minimizes the peak inrush current's stress on the power system. Peak starting torque can be managed to diminish mechanical system wear and damage.
- 24 Vac/Vdc control voltage enhances personnel and equipment safety. 110/230 Vac control voltage is also available
- Auxiliary relays indicate status of the soft start controllers
  - The TOR relay is active until motor stop command is received and/or the soft start controller detects a fault condition
  - RUN relay is active during the start ramp, bypass, and stop ramp

### Single-Phase Applications

All DS7 frame sizes can be configured for single-phase operation at 200–480 Vac main voltages in accordance to the single-phase application note AP039006EN.

### Standards and Certifications

- IEC 60947-4-2
- EN 60947-4-2
- UL® listed
- CSA certified
- CE marked
- C-Tick



### Instructional Leaflets

- Instruction Leaflet IL03901001E

### Protective Features

- Mains connection—The mains connection is monitored for a phase loss and/or undervoltage during ramp up
- Motor connection—The motor connection is monitored for an open condition during the ramp
- SCR faults—SCR performance is monitored during the ramp cycle for proper operation
- Heat sink over/under temperature—High ambient temperatures, extended ramp times, and high duty cycle conditions may cause the DS7 to exceed its thermal rating. When temperature goes under  $-5^{\circ}\text{C}$  ( $-40^{\circ}\text{C}$  for low temperature units), unit will trip as well. The DS7 is equipped with sensors that monitor the temperature of the device as well. The soft starter will trip in over/under temperature conditions, preventing device failure
- Warning is indicated for an over temperature condition for the next start
- Bypass relay
  - The DS7 can detect if the bypass relay fails to close after the ramp start or opens while the motor is running
  - The DS7 will also detect a condition whereas the bypass relay is closed when the RUN command is given
  - The DS7 will trip on a bypass dropout fault if either of these conditions occur

#### 1

### Catalog Number Selection

#### DS7 Soft Start Controllers

**DS7 - 3 4 0 SX 004 N 0 - N**

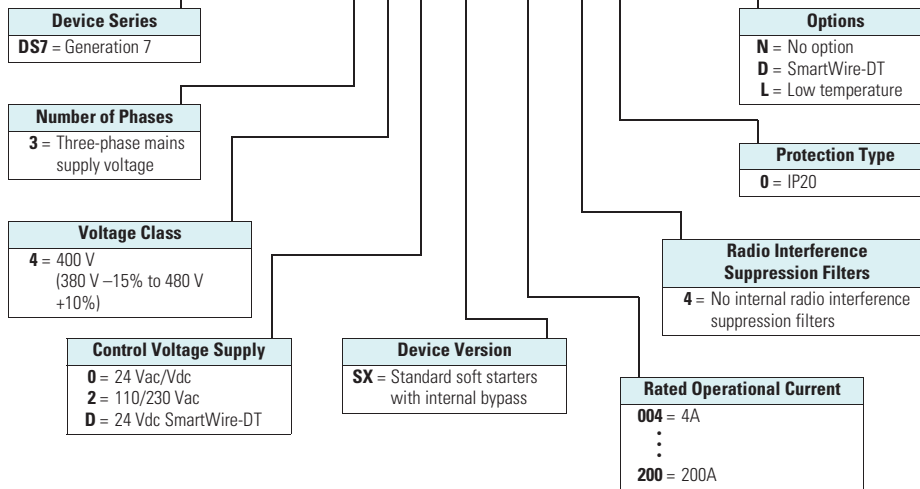

### Product Selection

#### DS7 Soft Start Horsepower Ratings

Please refer to Application Note AP039004EN for additional information on proper size selection.

DS7 Soft Start Controller—  
Frames 1 and 2



#### DS7 Soft Start Controllers—Horsepower Ratings— 10 Second Ramp, One Start per Hour, 300% Current Limit at 40 °C ①

Rated Current (A)	Motor Power (hp)			Maximum Allowable Breaker Size	Maximum Allowable Fuse Size	Recommended XTOB Overload (Direct Connect) ②	Recommended XTOE Overload ②		MMP ②	MMP ②	Connection Kit to MMP	Catalog Number
	200 V	230 V	480 V				PKE	MMP				
3.7	0.75	0.75	2	HFD3015	15A Class RK5	XTOB004BC1	XTOE005BCS	XTPE012BCS	XTPR004BC1	XTPAXTPCB	<b>DS7-340SX004N0-N</b> ④⑤	
											<b>DS7-342SX004N0-N</b> ⑥	
											<b>DS7-34DSX004N0-D</b> ⑦	
6.9	1.5	2	3	HFD3015	15A Class RK5	XTOB006BC1 ③	XTOE020BCS	XTPE012BCS	XTPR06P3BC1	XTPAXTPCB	<b>DS7-340SX007N0-N</b> ④⑤	
											<b>DS7-342SX007N0-N</b> ⑥	
											<b>DS7-34DSX007N0-D</b> ⑦	
7.8	2	2	5	HFD3020	20A Class RK5	XTOB010BC1	XTOE020BCS	XTPE012BCS	XTPR010BC1	XTPAXTPCB	<b>DS7-340SX009N0-N</b> ④⑤	
											<b>DS7-342SX009N0-N</b> ⑥	
											<b>DS7-34DSX009N0-D</b> ⑦	
11	3	3	7.5	HFD3030	20A Class RK5	XTOB012BC1	XTOE020BCS	XTPE032BCS	XTPR012BC1	XTPAXTPCB	<b>DS7-340SX012N0-N</b> ④⑤	
											<b>DS7-342SX012N0-N</b> ⑥	
											<b>DS7-34DSX012N0-D</b> ⑦	
15.2	3	5	10	HFD3035	25A Class RK5	XTOB016CC1	XTOE020CCS	XTPE032BCS	XTPR016BC1	XTPAXTPCC	<b>DS7-340SX016N0-N</b> ④⑤	
											<b>DS7-342SX016N0-N</b> ⑥	
											<b>DS7-34DSX016N0-D</b> ⑦	
22	5	7.5	15	HFD3060	40A Class RK5	XTOB024CC1	XTOE045CCS	XTPE032BCS	XTPR025BC1	XTPAXTPCC	<b>DS7-340SX024N0-N</b> ④⑤	
											<b>DS7-342SX024N0-N</b> ⑥	
											<b>DS7-34DSX024N0-D</b> ⑦	
32	7.5	10	20	HFD3070	50A Class RK5	XTOB032CC1	XTOE045CCS	XTPE032BCS	XTPR032BC1	XTPAXTPCC	<b>DS7-340SX032N0-N</b> ④⑤	
											<b>DS7-342SX032N0-N</b> ⑥	
											<b>DS7-34DSX032N0-D</b> ⑦	

#### Notes

- ① Actual motor FLAs vary. Verify these devices cover the motor specific FLA.
- ② Selections are based on motor FLA value at 480 V.
- ③ Not to be used with 230 V.
- ④ 24 Vac/Vdc device.
- ⑤ -40 °C rated low temperature version available in 24 Vac/Vdc, change to "N0-L"
- ⑥ 110/230 Vac device.
- ⑦ 24 Vdc for SmartWire-DT device.

#### Considerations

1. Either XTOB, C306 or C440 series or equivalent overload protection devices may be selected.
2. Contactor is optional for normal applications. It is recommended for mains isolation.

#### Power Supply

Eaton's PSG and ELC power supplies are recommended as a compact and low-cost source for 24 Vdc power. The lightweight, DIN rail mounted devices have a wide input voltage range, and robust screw terminals make these power supplies easy to install and use. These power supplies are available in 1A and 2A models.

#### Power Supply Selection

Description	Catalog Number
85–264 V input and 24 Vdc output	<b>ELC-PS01</b>
100–240 V input and 24 Vdc output	<b>PSG60E</b>
400–500 V input and 24 Vdc output	<b>PSG60F24RM</b>

Please refer to Application Note AP039004EN for additional information on proper size selection.

DS7 Soft Start Controller—  
Frames 3 and 4



### DS7 Soft Start Controllers—Horsepower Ratings— 10 Second Ramp, One Start per Hour, 300% Current Limit at 40 °C

Rated Current (A)	Motor Power (hp)			Maximum Allowable Breaker Size ①	Maximum Allowable Fuse Size ①	Recommended XTOB Overload	Recommended C440 Overload	Catalog Number
	200 V	230 V	460 V					
40	10	10	30	HFD3150L	150A Class RK5	XTOB040DC1 ②	C440A1A045SAX	DS7-340SX041N0-N ⑤⑥
								DS7-342SX041N0-N ⑦
								DS7-34DSX041N0-D ⑧
52	15	20	40	HFD3200L	200A Class RK5	XTOB057DC1 ②	C440B1A100SAX	DS7-340SX055N0-N ⑤⑥
								DS7-342SX055N0-N ⑦
								DS7-34DSX055N0-D ⑧
65	20	25	50	HJD3250	200A Class RK5	XTOB065DC1 ②	C440B1A100SAX	DS7-340SX070N0-N ⑤⑥
								DS7-342SX070N0-N ⑦
								DS7-34DSX070N0-D ⑧
77	25	30	60	HKD3300	300A Class RK5	XTOB100GC1S	C440B1A100SAX	DS7-340SX081N0-N ⑤⑥
								DS7-342SX081N0-N ⑦
								DS7-34DSX081N0-D ⑧
96	30	30	75	HKD3350	350A Class RK5	XTOB100GC1S	C440B1A100SAX	DS7-340SX100N0-N ⑤⑥
								DS7-342SX100N0-N ⑦
								DS7-34DSX100N0-D ⑧
124	40	50	100	HKD3400	500A Class RK5	XTOB125GC1S	C440A1A005SAX ④	DS7-340SX135N0-N ⑤⑥
								DS7-342SX135N0-N ⑦
								DS7-34DSX135N0-D ⑧
156	50	60	125	HLD3450	500A Class RK5	XTOB160LC1 ③	C440A1A005SAX ④	DS7-340SX160N0-N ⑤⑥
								DS7-342SX160N0-N ⑦
								DS7-34DSX160N0-D ⑧
180	60	75	150	HLD3500	500A Class RK5	XTOB220LC1 ③	C440A1A005SAX ④	DS7-340SX200N0-N ⑤⑥
								DS7-342SX200N0-N ⑦
								DS7-34DSX200N0-D ⑧

#### Notes

- ① Maximum values may be higher than allowed per NEC® 430.52 and UL 508A 31.1.
- ② XTOBXDIND Panel Mounting Adapter must be used with this overload.
- ③ XTOBXTLL line and load lugs must be used with this overload.
- ④ ZEB-XCT300 current transformer must be used with this overload.
- ⑤ 24 Vac/Vdc device.
- ⑥ -40 °C rated low temperature version available in 24 Vac/Vdc, change to "N0-L."
- ⑦ 110/230 Vac device.
- ⑧ 24 Vdc for SmartWire-DT device.

#### Considerations

1. Either XTOB, C306 or C440 series or equivalent overload protection devices may be selected.
2. Contactor is optional for normal applications. It is recommended for mains isolation.

#### Power Supply

Eaton's PSG and ELC power supplies are recommended as a compact and low-cost source for 24 Vdc power. The lightweight, DIN rail mounted devices have a wide input voltage range, and robust screw terminals make these power supplies easy to install and use. These power supplies are available in 1A and 2A models.

#### Power Supply Selection

Description	Catalog Number
85–264 V input and 24 Vdc output	ELC-PS01
100–240 V input and 24 Vdc output	PSG60E
400–500 V input and 24 Vdc output	PSG60F24RM

Please refer to Application Note AP039004EN for additional information on proper size selection.

**DS7 Soft Start Controller—  
Frames 1 and 2**



**DS7 Soft Start Controllers—Horsepower Ratings—  
10 Second Ramp, One Start per Hour, 400% Current Limit at 40 °C ①**

Rated Current (A)	Motor Power (hp)			Maximum Allowable Breaker Size	Maximum Allowable Fuse Size	Recommended XTOB Overload (Direct Connect) ②	Recommended XTOE Overload ②	PKE MMP	MMP ②	Connection Kit to MMP	Catalog Number
	200 V	230 V	480 V								
3	0.5	0.5	1.5	HFD3015	15A Class RK5	XTOB004BC1	XTOE005BCS	XTPE012BCS	XTPR004BC1	XTPAXTPCB	DS7-340SX004N0-N ④⑤
											DS7-342SX004N0-N ⑤
											DS7-34DSX004N0-D ⑥
4.8	1	1	3	HFD3015	15A Class RK5	XTOB006BC1 ③	XTOE020BCS	XTPE012BCS	XTPR06P3BC1	XTPAXTPCB	DS7-340SX007N0-N ④⑤
											DS7-342SX007N0-N ⑤
											DS7-34DSX007N0-D ⑥
6.9	1.5	2	3	HFD3020	20A Class RK5	XTOB006BC1	XTOE020BCS	XTPE012BCS	XTPR06P3BC1	XTPAXTPCB	DS7-340SX009N0-N ④⑤
											DS7-342SX009N0-N ⑤
											DS7-34DSX009N0-D ⑥
9	2	2	5	HFD3030	20A Class RK5	XTOB010BC1	XTOE020BCS	XTPE032BCS	XTPR010BC1	XTPAXTPCB	DS7-340SX012N0-N ④⑤
											DS7-342SX012N0-N ⑤
											DS7-34DSX012N0-D ⑥
11	3	3	7.5	HFD3035	25A Class RK5	XTOB016CC1	XTOE020CCS	XTPE032BCS	XTPR016BC1	XTPAXTPCC	DS7-340SX016N0-N ④⑤
											DS7-342SX016N0-N ⑤
											DS7-34DSX016N0-D ⑥
17.5	5	5	10	HFD3060	40A Class RK5	XTOB016CC1	XTOE045CCS	XTPE032BCS	XTPR016BC1	XTPAXTPCC	DS7-340SX024N0-N ④⑤
											DS7-342SX024N0-N ⑤
											DS7-34DSX024N0-D ⑥
22	5	7.5	15	HFD3070	50A Class RK5	XTOB024CC1	XTOE045CCS	XTPE032BCS	XTPR025BC1	XTPAXTPCC	DS7-340SX032N0-N ④⑤
											DS7-342SX032N0-N ⑤
											DS7-34DSX032N0-D ⑥

**Notes**

- ① Actual motor FLAs vary. Verify these devices cover the motor specific FLA.
- ② Selections are based on motor FLA value at 480 V.
- ③ Not to be used with 230 V.
- ④ 24 Vac/Vdc device.
- ⑤ -40 °C rated low temperature version available in 24 Vac/Vdc, change to "N0-L."
- ⑥ 110/230 Vac device.
- ⑦ 24 Vdc for SmartWire-DT device.

**Considerations**

1. Either XTOB, C306 or C440 series or equivalent overload protection devices may be selected.
2. Contactor is optional for normal applications. It is recommended for mains isolation.

**Power Supply**

Eaton's PSG and ELC power supplies are recommended as a compact and low-cost source for 24 Vdc power. The lightweight, DIN rail mounted devices have a wide input voltage range, and robust screw terminals make these power supplies easy to install and use. These power supplies are available in 1A and 2A models.

**Power Supply Selection**

Description	Catalog Number
85–264 V input and 24 Vdc output	ELC-PS01
100–240 V input and 24 Vdc output	PSG60E
400–500 V input and 24 Vdc output	PSG60F24RM

Please refer to Application Note AP039004EN for additional information on proper size selection.

DS7 Soft Start Controller—  
Frames 3 and 4



### DS7 Soft Start Controllers—Horsepower Ratings— 10 Second Ramp, One Start per Hour, 400% Current Limit at 40 °C

Rated Current (A)	Motor Power (hp)			Maximum Allowable Breaker Size ①	Maximum Allowable Fuse Size ①	Recommended XTOB Overload	Recommended C440 Overload	Catalog Number
	200 V	230 V	460 V					
27	7.5	10	20	HFD3150L	150A Class RK5	XTOB040DC1	C440A1A045SAX	DS7-340SX041N0-N ④⑤
								DS7-342SX041N0-N ⑥
								DS7-34DSX041N0-D ⑦
34	10	10	30	HFD3200L	200A Class RK5	XTOB040DC1	C440A1A045SAX	DS7-340SX055N0-N ④⑤
								DS7-342SX055N0-N ⑥
								DS7-34DSX055N0-D ⑦
40	15	15	30	HJD3250	200A Class RK5	XTOB057DC1 ②	C440A1A045SAX	DS7-340SX070N0-N ④⑤
								DS7-342SX070N0-N ⑥
								DS7-34DSX070N0-D ⑦
52	15	20	40	HKD3300	300A Class RK5	XTOB057DC1 ②	C440B1A100SAX	DS7-340SX081N0-N ④⑤
								DS7-342SX081N0-N ⑥
								DS7-34DSX081N0-D ⑦
65	20	25	50	HKD3350	350A Class RK5	XTOB100GC1S	C440B1A100SAX	DS7-340SX100N0-N ④⑤
								DS7-342SX100N0-N ⑥
								DS7-34DSX100N0-D ⑦
80	30	30	75	HKD3350	500A Class RK5	XTOB100GC1S	C440B1A100SAX	DS7-340SX135N0-N ④⑤
								DS7-342SX135N0-N ⑥
								DS7-34DSX135N0-D ⑦
96	30	40	75	HLD3450	500A Class RK5	XTOB100GC1S	C440B1A100SAX	DS7-340SX160N0-N ④⑤
								DS7-342SX160N0-N ⑥
								DS7-34DSX160N0-D ⑦
124	40	50	100	HLD3500	500A Class RK5	XTOB150GC1S	C440A1A005SAX ③	DS7-340SX200N0-N ④⑤
								DS7-342SX200N0-N ⑥
								DS7-34DSX200N0-D ⑦

#### Notes

- ① Maximum values may be higher than allowed per NEC® 430.52 and UL 508A 31.1.
- ② XTOBXDIND Panel Mounting Adapter must be used with this overload.
- ③ ZEB-XCT300 current transformer must be used with this overload.
- ④ 24 Vac/Vdc device.
- ⑤ -40 °C rated low temperature version available in 24 Vac/Vdc, change to "NO-L."
- ⑥ 110/230 Vac device.
- ⑦ 24 Vdc for SmartWire-DT device.

#### Considerations

1. Either XTOB, C306 or C440 series or equivalent overload protection devices may be selected.
2. Contactor is optional for normal applications. It is recommended for mains isolation.

#### Power Supply

Eaton's PSG and ELC power supplies are recommended as a compact and low-cost source for 24 Vdc power. The lightweight, DIN rail mounted devices have a wide input voltage range, and robust screw terminals make these power supplies easy to install and use. These power supplies are available in 1A and 2A models.

#### Power Supply Selection

Description	Catalog Number
85–264 V input and 24 Vdc output	ELC-PS01
100–240 V input and 24 Vdc output	PSG60E
400–500 V input and 24 Vdc output	PSG60F24RM



### DS7 Soft Start kW Ratings

Please refer to Application Note AP039004EN for additional information on proper size selection.

DS7 Soft Start Controller—  
Frames 1 and 2



### DS7 Soft Start Controllers—kW Ratings According to IEC 60947-4-2— 10 Second Ramp, One Start per Hour, 300% Current Limit at 40 °C ①

Rated Current (A)	Motor Power (kW)		Maximum Allowable Breaker Size	Maximum Allowable Fuse Size	Recommended XTOB Overload (Direct Connect) ②	Recommended XTOE Overload ②	PKE MMP	MMP ②	Connection Kit to MMP	Catalog Number
	230 V	400 V								
3.8	0.75	1.5	HFD3015	15A Class RK5	XTOB004BC1	XTOE005BCS	XTPe012BCS	XTPR004BC1	XTPAXTPCB	DS7-340SX004N0-N ④⑤
										DS7-342SX004N0-N ⑥
										DS7-34DSX004N0-D ⑦
7	1.5	3	HFD3015	15A Class RK5	XTOB006BC1 ③	XTOE020BCS	XTPe012BCS	XTPR6P3BC1	XTPAXTPCB	DS7-340SX007N0-N ④⑤
										DS7-342SX007N0-N ⑥
										DS7-34DSX007N0-D ⑦
9	2.2	4	HFD3020	20A Class RK5	XTOB010BC1	XTOE020BCS	XTPe012BCS	XTPR010BC1	XTPAXTPCB	DS7-340SX009N0-N ④⑤
										DS7-342SX009N0-N ⑥
										DS7-34DSX009N0-D ⑦
12	3	5.5	HFD3030	20A Class RK5	XTOB012BC1	XTOE020BCS	XTPe032BCS	XTPR012BC1	XTPAXTPCB	DS7-340SX012N0-N ④⑤
										DS7-342SX012N0-N ⑥
										DS7-34DSX012N0-D ⑦
16	4	7.5	HFD3035	25A Class RK5	XTOB016CC1	XTOE020CCS	XTPe032BCS	XTPR016BC1	XTPAXTPCC	DS7-340SX016N0-N ④⑤
										DS7-342SX016N0-N ⑥
										DS7-34DSX016N0-D ⑦
24	5.5	11	HFD3060	40A Class RK5	XTOB024CC1	XTOE045CCS	XTPe032BCS	XTPR025BC1	XTPAXTPCC	DS7-340SX024N0-N ④⑤
										DS7-342SX024N0-N ⑥
										DS7-34DSX024N0-D ⑦
32	7.5	15	HFD3070	50A Class RK5	XTOB032CC1	XTOE045CCS	XTPe032BCS	XTPR032BC1	XTPAXTPCC	DS7-340SX032N0-N ④⑤
										DS7-342SX032N0-N ⑥
										DS7-34DSX032N0-D ⑦

#### Notes

- ① Actual motor FLAs vary. Verify these devices cover the motor specific FLA.
- ② Selections are based on motor FLA value at 480 V.
- ③ Not to be used with 230 V.
- ④ 24 Vac/Vdc device.
- ⑤ -40 °C rated low temperature version available in 24 Vac/Vdc, change to "NO-L."
- ⑥ 110/230 Vac device.
- ⑦ 24 Vdc for SmartWire-DT device.

#### Considerations

1. Either XTOB, C306 or C440 series or equivalent overload protection devices may be selected.
2. Contactor is optional for normal applications. It is recommended for mains isolation.

#### Power Supply

Eaton's PSG and ELC power supplies are recommended as a compact and low-cost source for 24 Vdc power. The lightweight, DIN rail mounted devices have a wide input voltage range, and robust screw terminals make these power supplies easy to install and use. These power supplies are available in 1A and 2A models.

#### Power Supply Selection

Description	Catalog Number
85–264 V input and 24 Vdc output	ELC-PS01
100–240 V input and 24 Vdc output	PSG60E
400–500 V input and 24 Vdc output	PSG60F24RM

Please refer to Application Note AP039004EN for additional information on proper size selection.

DS7 Soft Start Controller—  
Frames 3 and 4



### DS7 Soft Start Controllers—kW Ratings According to IEC 60947-4-2— 10 Second Ramp, One Start per Hour, 300% Current Limit at 40 °C

Rated Current (A)	Motor Power (kW)		Maximum Allowable Breaker Size <sup>①</sup>	Maximum Allowable Fuse Size <sup>①</sup>	Recommended XTOB Overload	Recommended C440 Overload	Catalog Number
	230 V	400 V					
41	11	22	HFD3150L	150A Class RK5	XTOB057DC1 <sup>②</sup>	C440A1A045SAX	DS7-340SX041N0-N <sup>⑤⑥</sup>
							DS7-342SX041N0-N <sup>⑦</sup>
							DS7-34DSX041N0-D <sup>⑧</sup>
55	15	30	HFD3200L	200A Class RK5	XTOB057DC1 <sup>②</sup>	C440B1A100SAX	DS7-340SX055N0-N <sup>⑤⑥</sup>
							DS7-342SX055N0-N <sup>⑦</sup>
							DS7-34DSX055N0-D <sup>⑧</sup>
68	15	37	HJD3250	200A Class RK5	XTOB070GC1 <sup>②</sup>	C440B1A100SAX	DS7-340SX070N0-N <sup>⑤⑥</sup>
							DS7-342SX070N0-N <sup>⑦</sup>
							DS7-34DSX070N0-D <sup>⑧</sup>
81	22	45	HKD3300	300A Class RK5	XTOB100GC1S	C440B1A100SAX	DS7-340SX081N0-N <sup>⑤⑥</sup>
							DS7-342SX081N0-N <sup>⑦</sup>
							DS7-34DSX081N0-D <sup>⑧</sup>
99	30	55	HKD3350	350A Class RK5	XTOB100GC1S	C440B1A100SAX	DS7-340SX100N0-N <sup>⑤⑥</sup>
							DS7-342SX100N0-N <sup>⑦</sup>
							DS7-34DSX041N0-D <sup>⑧</sup>
134	30	75	HKD3400	500A Class RK5	XTOB150GC1S	C440A1A005SAX <sup>④</sup>	DS7-340SX135N0-N <sup>⑤⑥</sup>
							DS7-342SX135N0-N <sup>⑦</sup>
							DS7-34DSX135N0-D <sup>⑧</sup>
160	45	90	HLD3450	500A Class RK5	XTOB160LC1 <sup>③</sup>	C440A1A005SAX <sup>④</sup>	DS7-340SX160N0-N <sup>⑤⑥</sup>
							DS7-342SX160N0-N <sup>⑦</sup>
							DS7-34DSX160N0-D <sup>⑧</sup>
196	55	110	HLD3500	500A Class RK5	XTOB220LC1 <sup>③</sup>	C440A1A005SAX <sup>④</sup>	DS7-340SX200N0-N <sup>⑤⑥</sup>
							DS7-342SX200N0-N <sup>⑦</sup>
							DS7-34DSX200N0-D <sup>⑧</sup>

#### Notes

- ① Maximum values may be higher than allowed per NEC 430.52 and UL 508A 31.1.
- ② XTOBXDIND Panel Mounting Adapter must be used with this overload.
- ③ XTOBXTLL line and load lugs must be used with this overload.
- ④ ZEB-XCT300 current transformer must be used with this overload.
- ⑤ 24 Vac/Vdc device.
- ⑥ -40 °C rated low temperature version available in 24 Vac/Vdc, change to "NO-L."
- ⑦ 110/230 Vac device.
- ⑧ 24 Vdc for SmartWire-DT device.

#### Considerations

1. Either XTOB, C306 or C440 series or equivalent overload protection devices may be selected.
2. Contactor is optional for normal applications. It is recommended for mains isolation.

#### Power Supply

Eaton's PSG and ELC power supplies are recommended as a compact and low-cost source for 24 Vdc power. The lightweight, DIN rail mounted devices have a wide input voltage range, and robust screw terminals make these power supplies easy to install and use. These power supplies are available in 1A and 2A models.

#### Power Supply Selection

Description	Catalog Number
85–264 V input and 24 Vdc output	ELC-PS01
100–240 V input and 24 Vdc output	PSG60E
400–500 V input and 24 Vdc output	PSG60F24RM

Please refer to Application Note AP039004EN for additional information on proper size selection.

**DS7 Soft Start Controller—  
Frames 1 and 2**



**DS7 Soft Start Controllers—kW Ratings According to IEC 60947-4-2—  
10 Second Ramp, One Start per Hour, 400% Current Limit at 40 °C ①**

Rated Current (A)	Motor Power (kW)		Maximum Allowable Breaker Size	Maximum Allowable Fuse Size	Recommended XTOB Overload (Direct Connect) ②	Recommended XTOE Overload ②	PKE MMP	MMP ②	Connection Kit to MMP	Catalog Number
	230 V	400 V								
2.5	0.33	1	HFD3015	15A Class RK5	XTOB004BC1	XTOE005BCS	XTPE012BCS	XTPR004BC1	XTPAXTPCB	<b>DS7-340SX004N0-N</b> ④⑤
										<b>DS7-342SX004N0-N</b> ⑥
										<b>DS7-34DSX004N0-D</b> ⑦
3.8	0.75	1.5	HFD3015	15A Class RK5	XTOB006BC1 ③	XTOE020BCS	XTPE012BCS	XTPR6P3BC1	XTPAXTPCB	<b>DS7-340SX007N0-N</b> ④⑤
										<b>DS7-342SX007N0-N</b> ⑥
										<b>DS7-34DSX007N0-D</b> ⑦
7	1.5	3	HFD3020	20A Class RK5	XTOB006BC1	XTOE020BCS	XTPE012BCS	XTPR6P3BC1	XTPAXTPCB	<b>DS7-340SX009N0-N</b> ④⑤
										<b>DS7-342SX009N0-N</b> ⑥
										<b>DS7-34DSX009N0-D</b> ⑦
9	2.2	4	HFD3030	20A Class RK5	XTOB010BC1	XTOE020BCS	XTPE032BCS	XTPR010BC1	XTPAXTPCB	<b>DS7-340SX012N0-N</b> ④⑤
										<b>DS7-342SX012N0-N</b> ⑥
										<b>DS7-34DSX012N0-D</b> ⑦
12	3	5.5	HFD3035	25A Class RK5	XTOB016CC1	XTOE020CCS	XTPE032BCS	XTPR016BC1	XTPAXTPCC	<b>DS7-340SX016N0-N</b> ④⑤
										<b>DS7-342SX016N0-N</b> ⑥
										<b>DS7-34DSX016N0-D</b> ⑦
16	4	7.5	HFD3060	40A Class RK5	XTOB016CC1	XTOE045CCS	XTPE032BCS	XTPR016BC1	XTPAXTPCC	<b>DS7-340SX024N0-N</b> ④⑤
										<b>DS7-342SX024N0-N</b> ⑥
										<b>DS7-34DSX016N0-D</b> ⑦
24	5.5	11	HFD3070	50A Class RK5	XTOB024CC1	XTOE045CCS	XTPE032BCS	XTPR025BC1	XTPAXTPCC	<b>DS7-340SX032N0-N</b> ④⑤
										<b>DS7-342SX032N0-N</b> ⑥
										<b>DS7-34DSX032N0-D</b> ⑦

**Notes**

- ① Actual motor FLAs vary. Verify these devices cover the motor specific FLA.
- ② Selections are based on motor FLA value at 480 V.
- ③ Not to be used with 230 V.
- ④ 24 Vac/Vdc device.
- ⑤ -40 °C rated low temperature version available in 24 Vac/Vdc, change to "N0-L."
- ⑥ 110/230 Vac device.
- ⑦ 24 Vdc for SmartWire-DT device.

**Considerations**

1. Either XTOB, C306 or C440 series or equivalent overload protection devices may be selected.
2. Contactor is optional for normal applications. It is recommended for mains isolation.

**Power Supply**

Eaton's PSG and ELC power supplies are recommended as a compact and low-cost source for 24 Vdc power. The lightweight, DIN rail mounted devices have a wide input voltage range, and robust screw terminals make these power supplies easy to install and use. These power supplies are available in 1A and 2A models.

**Power Supply Selection**

Description	Catalog Number
85–264 V input and 24 Vdc output	<b>ELC-PS01</b>
100–240 V input and 24 Vdc output	<b>PSG60E</b>
400–500 V input and 24 Vdc output	<b>PSG60F24RM</b>

Please refer to Application Note AP039004EN for additional information on proper size selection.

DS7 Soft Start Controller—  
Frames 3 and 4



### DS7 Soft Start Controllers—kW Ratings According to IEC 60947-4-2— 10 Second Ramp, One Start per Hour, 400% Current Limit at 40 °C

Rated Current (A)	Motor Power (kW)		Maximum Allowable Breaker Size ①	Maximum Allowable Fuse Size ①	Recommended XTOB Overload	Recommended C440 Overload	Catalog Number
	230 V	400 V					
28.8	7.5	11	HFD3150L	150A Class RK5	XTOB040DC1	C440A1A045SAX	DS7-340SX041N0-N ⑤⑥
							DS7-342SX041N0-N ⑦
							DS7-34DSX041N0-D ⑧
37.5	11	18.5	HFD3200L	200A Class RK5	XTOB040DC1	C440A1A045SAX	DS7-340SX055N0-N ⑤⑥
							DS7-342SX055N0-N ⑦
							DS7-34DSX055N0-D ⑧
46	11	22	HJD3250	200A Class RK5	XTOB057DC1 ②	C440B1A100SAX	DS7-340SX070N0-N ⑤⑥
							DS7-342SX070N0-N ⑦
							DS7-34DSX070N0-D ⑧
56	15	30	HKD3300	300A Class RK5	XTOB065DC1 ②	C440B1A100SAX	DS7-340SX081N0-N ⑤⑥
							DS7-342SX081N0-N ⑦
							DS7-34DSX081N0-D ⑧
68	18.5	37	HKD3350	350A Class RK5	XTOB100GC1S	C440B1A100SAX	DS7-340SX100N0-N ⑤⑥
							DS7-342SX100N0-N ⑦
							DS7-34DSX100N0-D ⑧
90	22	45	HKD3350	500A Class RK5	XTOB100GC1S	C440B1A100SAX	DS7-340SX135N0-N ⑤⑥
							DS7-342SX135N0-N ⑦
							DS7-34DSX135N0-D ⑧
106	30	55	HLD3450	500A Class RK5	XTOB160LC1 ③	C440A1A005SAX ④	DS7-340SX160N0-N ⑤⑥
							DS7-342SX160N0-N ⑦
							DS7-34DSX160N0-D ⑧
134	37	75	HLD3500	500A Class RK5	XTOB160LC1 ③	C440A1A005SAX ④	DS7-340SX200N0-N ⑤⑥
							DS7-342SX200N0-N ⑦
							DS7-34DSX200N0-D ⑧

#### Notes

- ① Maximum values may be higher than allowed per NEC 430.52 and UL 508A 31.1.
- ② XTOBXDIND Panel Mounting Adapter must be used with this overload.
- ③ XTOBXTLL line and load lugs must be used with this overload.
- ④ ZEB-XCT300 current transformer must be used with this overload.
- ⑤ 24 Vac/Vdc device.
- ⑥ -40 °C rated low temperature version available in 24 Vac/Vdc, change to "N0-L."
- ⑦ 110/230 Vac device.
- ⑧ 24 Vdc for SmartWire-DT device.

#### Considerations

1. Either XTOB, C306 or C440 series or equivalent overload protection devices may be selected.
2. Contactor is optional for normal applications. It is recommended for mains isolation.

#### Power Supply

Eaton's PSG and ELC power supplies are recommended as a compact and low-cost source for 24 Vdc power. The lightweight, DIN rail mounted devices have a wide input voltage range, and robust screw terminals make these power supplies easy to install and use. These power supplies are available in 1A and 2A models.

#### Power Supply Selection

Description	Catalog Number
85–264 V input and 24 Vdc output	ELC-PS01
100–240 V input and 24 Vdc output	PSG60E
400–500 V input and 24 Vdc output	PSG60F24RM

### Accessories

#### Device Fans

#### DS7-FAN-032



Description	For Use With ...	Std. Pack	Catalog Number
Device fan for increasing the load cycle (more starts per hour higher or longer ramp times exceeding 10 seconds.	DS7-34...SX004...	1 off	<b>DS7-FAN-032</b> ①
	DS7-34...SX007...		
	DS7-34...SX009...		
	DS7-34...SX012...		
	DS7-34...SX016...		
	DS7-34...SX024...		
	DS7-34...SX032...		

#### Note

① NA Certification. Request filed for UL and CSA.

## Technical Data and Specifications

### DS7 Soft Start Controllers

#### Rated Control Circuit

Voltage 24 Vac/Vdc  
Voltage 110/230 Vac  
Voltage 24 Vdc

Unit	DS7-340SX004N0-N DS7-342SX004N0-N DS7-34DSX004N0-D	DS7-340SX007N0-N DS7-342SX007N0-N DS7-34DSX007N0-D	DS7-340SX009N0-N DS7-342SX009N0-N DS7-34DSX009N0-D	DS7-340SX012N0-N DS7-342SX012N0-N DS7-34DSX012N0-D
------	--	--	--	--

#### General

Standards		IEC/EN 60947-4-2; GB14048.6; UL508; CSA-C22.2 No 0-M91; CSA-C22.2 No 14-05 CE marking	IEC/EN 60947-4-2; GB14048.6; UL508; CSA-C22.2 No 0-M91; CSA-C22.2 No 14-05 CE marking	IEC/EN 60947-4-2; GB14048.6; UL508; CSA-C22.2 No 0-M91; CSA-C22.2 No 14-05 CE marking	IEC/EN 60947-4-2; GB14048.6; UL508; CSA-C22.2 No 0-M91; CSA-C22.2 No 14-05 CE marking
Certifications/markings		UL/CE/CSA/C-Tick	UL/CE/CSA/C-Tick	UL/CE/CSA/C-Tick	UL/CE/CSA/C-Tick
Ambient temperature (operation)	°C	0 to 40 °C, above 40 °C de-rate linearly by 1% of rated current per Celsius to 60 °C -40 to +40 °C for low temperature version	0 to 40 °C, above 40 °C de-rate linearly by 1% of rated current per Celsius to 60 °C -40 to +40 °C for low temperature version	0 to 40 °C, above 40 °C de-rate linearly by 1% of rated current per Celsius to 60 °C -40 to +40 °C for low temperature version	0 to 40 °C, above 40 °C de-rate linearly by 1% of rated current per Celsius to 60 °C -40 to +40 °C for low temperature version
Ambient temperature (storage)	°C	-25 to 55 °C	-25 to 55 °C	-25 to 55 °C	-25 to 55 °C
Altitude		0–1000m, above 1000m de-rate linearly by 2.5% of rated current per 100m to a maximum of 2000m	0–1000m, above 1000m de-rate linearly by 2.5% of rated current per 100m to a maximum of 2000m	0–1000m, above 1000m de-rate linearly by 2.5% of rated current per 100m to a maximum of 2000m	0–1000m, above 1000m de-rate linearly by 2.5% of rated current per 100m to a maximum of 2000m
Installation		Vertical	Vertical	Vertical	Vertical
Protection class		IP20	IP20	IP20	IP20
Protection class applies to the front and operator control and display elements. Protection type from all sides is IP00.		With optional covers from the NZM range, protection type IP40 from all sides can be achieved	With optional covers from the NZM range, protection type IP40 from all sides can be achieved	With optional covers from the NZM range, protection type IP40 from all sides can be achieved	With optional covers from the NZM range, protection type IP40 from all sides can be achieved
Busbar tag shroud		Back of hand and finger-proof (from front face)	Back of hand and finger-proof (from front face)	Back of hand and finger-proof (from front face)	Back of hand and finger-proof (from front face)
Overvoltage category/pollution degree		II/2	II/2	II/2	II/2
Shock resistance		8g/11ms	8g/11ms	8g/11ms	8g/11ms
Vibration resistance according to EN 60721-3-2		2M2	2M2	2M2	2M2
Mean heat dissipation at rated duty cycle	W	0.2	0.35	0.35	0.6
Radio interference		B	B	B	B
Dimensions (W x H x D)					
DS7-340... and DS7-342...	in (mm)	1.77 x 5.12 x 3.74 (45 x 130 x 95)	1.77 x 5.12 x 3.74 (45 x 130 x 95)	1.77 x 5.12 x 3.74 (45 x 130 x 95)	1.77 x 5.12 x 3.74 (45 x 130 x 95)
DS7-34D...	in (mm)	1.77 x 5.31 x 3.74 (45 x 135 x 95)	1.77 x 5.31 x 3.74 (45 x 135 x 95)	1.77 x 5.31 x 3.74 (45 x 135 x 95)	1.77 x 5.31 x 3.74 (45 x 135 x 95)
Weight					
DS7-340...	lb (kg)	0.77 (0.35)	0.77 (0.35)	0.77 (0.35)	0.77 (0.35)
DS7-342...	lb (kg)	0.88 (0.40)	0.88 (0.40)	0.88 (0.40)	0.88 (0.40)
DS7-34D...	lb (kg)	0.90 (0.41)	0.90 (0.41)	0.90 (0.41)	0.90 (0.41)
<b>Main Circuit</b>					
Rated operational voltage	V	230–460 Vac	230–460 Vac	230–460 Vac	230–460 Vac
Mains frequency	Hz	50/60 Hz	50/60 Hz	50/60 Hz	50/60 Hz
Rated operation current AC 53	I <sub>e</sub>	4	7	9	12
<b>Motor Power Ratings</b>					
200 V	hp	0.75	1.5	2	3
230 V	hp	0.75	2	2	5
480 V	hp	2	3	5	10
230 V	kW	0.75	1.5	2.2	3
400 V	kW	1.5	3	4	5.5
Overload cycle according to EN 60947-4-2		4A: AC53a; 3-5; 75-10	7A: AC53a; 3-5; 75-10	9A: AC53a; 3-5; 75-10	12A: AC53a; 3-5; 75-10

### DS7 Soft Start Controllers, continued

#### Rated Control Circuit

		DS7-340SX004N0-N DS7-342SX004N0-N DS7-34DSX004N0-D	DS7-340SX007N0-N DS7-342SX007N0-N DS7-34DSX007N0-D	DS7-340SX009N0-N DS7-342SX009N0-N DS7-34DSX009N0-D	DS7-340SX012N0-N DS7-342SX012N0-N DS7-34DSX012N0-D
Voltage 24 Vac/Vdc					
Voltage 110/230 Vac					
Voltage 24 Vdc	Unit				

#### Wire Specifications

Power terminals					
Single conductor—solid or stranded	AWG	18–10	18–10	18–10	18–10
Terminal torque	lb-in	11	11	11	11
Control signals					
Single conductor—solid or stranded	AWG	18–10	18–10	18–10	18–10
Terminal torque	lb-in	11	11	11	11

#### Power Section

Rated impulse withstand voltage	$U_{imp}$ 1.2/50 s	4 kV	4 kV	4 kV	4 kV
Rated insulation voltage		500	500	500	500

#### Control Commands—Vac/Vdc

Supply voltage control board $U_s$ nominal	Vac/Vdc	20.4–26.4	20.4–26.4	20.4–26.4	20.4–26.4
Current consumption at 24 Vac/Vdc	mA	1.6	1.6	1.6	1.6
Pick-up voltage		+17.3–+27	+17.3–+27	+17.3–+27	+17.3–+27
Drop-out voltage		+3–0	+3–0	+3–0	+3–0

#### Relay Outputs

Number of relays		1 (TOR)	1 (TOR)	1 (TOR)	1 (TOR)
Maximum voltage	Vac	250	250	250	250
Maximum current	A	1A	1A	1A	1A

#### Soft Start Functions

Ramp times					
Start ramp	s	1–30	1–30	1–30	1–30
Stop ramp	s	0–30	0–30	0–30	0–30
Initial voltage % line voltage					
DS7-342...		30–92%	30–92%	30–92%	30–92%
DS7-340...		30–100%	30–100%	30–100%	30–100%
DS7-34D...		30–92%	30–92%	30–92%	30–92%

#### Control Commands—Vac

Supply voltage control board $U_s$ nominal	Vac	102–253	102–253	102–253	102–253
Current consumption at 24 Vac/Vdc	mA	4	4	4	4
Pick-up voltage	Vac	102–230	102–230	102–230	102–230
Drop-out voltage	Vac	0–28	0–28	0–28	0–28

#### Relay Outputs

Number of relays		1 (TOR)	1 (TOR)	1 (TOR)	1 (TOR)
Maximum voltage	Vac	250	250	250	250
Maximum current	A	3A	3A	3A	3A

#### Soft Start Functions

Ramp times					
Start ramp	s	1–30	1–30	1–30	1–30
Stop ramp	s	0–30	0–30	0–30	0–30
Initial voltage % line voltage					
		30–92%	30–92%	30–92%	30–92%

## DS7 Soft Start Controllers, continued

## Rated Control Circuit

Voltage 24 Vac/Vdc  
Voltage 110/230 Vac  
Voltage 24 Vdc

Unit

DS7-340SX016N0-N  
DS7-342SX016N0-N  
DS7-34DSX016N0-D

DS7-340SX024N0-N  
DS7-342SX024N0-N  
DS7-34DSX024N0-D

DS7-340SX032N0-N  
DS7-342SX032N0-N  
DS7-34DSX032N0-D

## General

Standards		IEC/EN 60947-4-2; GB14048.6; UL508; CSA-C22.2 No 0-M91; CSA-C22.2 No 14-05 CE marking	IEC/EN 60947-4-2; GB14048.6; UL508; CSA-C22.2 No 0-M91; CSA-C22.2 No 14-05 CE marking	IEC/EN 60947-4-2; GB14048.6; UL508; CSA-C22.2 No 0-M91; CSA-C22.2 No 14-05 CE marking
Certifications/markings		UL/CE/CSA/C-Tick	UL/CE/CSA/C-Tick	UL/CE/CSA/C-Tick
Ambient temperature (operation)	°C	0 to 40 °C, above 40 °C de-rate linearly by 1% of rated current per Celsius to 60 °C –40 to +40 °C for low temperature version	0 to 40 °C, above 40 °C de-rate linearly by 1% of rated current per Celsius to 60 °C –40 to +40 °C for low temperature version	0 to 40 °C, above 40 °C de-rate linearly by 1% of rated current per Celsius to 60 °C –40 to +40 °C for low temperature version
Ambient temperature (storage)	°C	–25 to 55 °C	–25 to 55 °C	–25 to 55 °C
Altitude		0–1000m, above 1000m de-rate linearly by 2.5% of rated current per 100m to a maximum of 2000m	0–1000m, above 1000m de-rate linearly by 2.5% of rated current per 100m to a maximum of 2000m	0–1000m, above 1000m de-rate linearly by 2.5% of rated current per 100m to a maximum of 2000m
Installation		Vertical	Vertical	Vertical
Protection class		IP20	IP20	IP20
Protection class applies to the front and operator control and display elements. Protection type from all sides is IP00.		With optional covers from the NZM range, protection type IP40 from all sides can be achieved	With optional covers from the NZM range, protection type IP40 from all sides can be achieved	With optional covers from the NZM range, protection type IP40 from all sides can be achieved
Busbar tag shroud		Back of hand and finger-proof (from front face)	Back of hand and finger-proof (from front face)	Back of hand and finger-proof (from front face)
Overvoltage category/ pollution degree		II/2	II/2	II/2
Shock resistance		8g/11ms	8g/11ms	8g/11ms
Vibration resistance according to EN 60721-3-2		2M2	2M2	2M2
Mean heat dissipation at rated duty cycle	W	0.8	1.1	1.5
Radio interference		B	B	B
Dimensions (W x H x D)				
DS7-340... and DS7-342...	in (mm)	1.77 x 5.91 x 4.65 (45 x 150 x 118)	1.77 x 5.91 x 4.65 (45 x 150 x 118)	1.77 x 5.91 x 4.65 (45 x 150 x 118)
DS7-34D...	in (mm)	1.77 x 5.91 x 4.65 (45 x 150 x 118)	1.77 x 5.91 x 4.65 (45 x 150 x 118)	1.77 x 5.91 x 4.65 (45 x 150 x 118)
Weight				
DS7-340...	lb (kg)	0.88 (0.40)	0.88 (0.40)	0.88 (0.40)
DS7-342...	lb (kg)	0.99 (0.45)	0.99 (0.45)	0.99 (0.45)
DS7-34D...	lb (kg)	0.90 (0.41)	0.90 (0.41)	0.90 (0.41)
<b>Main Circuit</b>				
Rated operational voltage	V	230–460 Vac	230–460 Vac	230–460 Vac
Mains frequency	Hz	50/60 Hz	50/60 Hz	50/60 Hz
Rated operation current AC 53	I <sub>e</sub>	16	24	32
<b>Motor Power Ratings</b>				
200 V	hp	3	5	10
230 V	hp	5	7.5	10
480 V	hp	10	15	25
230 V	kW	4	5.5	7.5
400 V	kW	7.5	11	15
Overload cycle according to EN 60947-4-2		16A: AC53a; 3-5; 75-10	24A: AC53a; 3-5; 75-10	32A: AC53a; 3-5; 75-10



### DS7 Soft Start Controllers, continued

#### Rated Control Circuit

Voltage 24 Vac/Vdc

Voltage 110/230 Vac

Voltage 24 Vdc

Unit

DS7-340SX016N0-N

DS7-342SX016N0-N

DS7-34DSX016N0-D

DS7-340SX024N0-N

DS7-342SX024N0-N

DS7-34DSX024N0-D

DS7-340SX032N0-N

DS7-342SX032N0-N

DS7-34DSX032N0-D

#### Wire Specifications

Power terminals

Single conductor—solid or stranded

AWG

18–6

18–6

18–6

Terminal torque

lb-in

11

11

11

Control Signals

Single conductor—solid or stranded

AWG

18–10

18–10

18–10

Terminal torque

lb-in

11

11

11

#### Power Section

Rated impulse withstand voltage

$U_{imp}$   
1.2/50 s

4 kV

4 kV

4 kV

Rated insulation voltage

500

500

500

#### Control Commands—Vac/Vdc

Supply voltage control board  $U_s$  nominal

Vac/Vdc

20.4–26.4

20.4–26.4

20.4–26.4

Current consumption at 24 Vac/Vdc

mA

1.6

1.6

1.6

Pick-up voltage

+17.3–+27

+17.3–+27

+17.3–+27

Drop-out voltage

+3–0

+3–0

+3–0

#### Relay Outputs

Number of relays

2 (TOR, Ready)

2 (TOR, Ready)

2 (TOR, Ready)

Maximum voltage

Vac

250

250

250

Maximum current

A

1A

1A

1A

#### Soft Start Functions

Ramp times

Start ramp

s

1–30

1–30

1–30

Stop ramp

s

0–30

0–30

0–30

Initial voltage % line voltage

DS7-342...

30–92%

30–92%

30–92%

DS7-340...

30–100%

30–100%

30–100%

DS7-34D...

30–92%

30–92%

30–92%

#### Control Commands—Vac

Supply voltage control board  $U_s$  nominal

Vac

102–253

102–253

102–253

Current consumption at 102–253 Vac

mA

4

4

4

Pick-up voltage

Vac

102–230

102–230

102–230

Drop-out voltage

Vac

0–28

0–28

0–28

#### Relay Outputs

Number of relays

2 (TOR, Run)

2 (TOR, Run)

2 (TOR, Run)

Maximum voltage

Vac

250

250

250

Maximum current

A

3A

3A

3A

#### Soft Start Functions

Ramp times

Start ramp

s

1–30

1–30

1–30

Stop ramp

s

0–30

0–30

0–30

Initial voltage % line voltage

30–92%

30–92%

30–92%

### Accessories

#### Device Fans

#### DS7-FAN-032



Description	For Use With ...	Std. Pack	Catalog Number
Device fan for increasing the load cycle (more starts per hour higher or longer ramp times exceeding 10 seconds).	DS7-34...SX004...	1 off	<b>DS7-FAN-032</b> ①
	DS7-34...SX007...		
	DS7-34...SX009...		
	DS7-34...SX012...		
	DS7-34...SX016...		
	DS7-34...SX024...		
	DS7-34...SX032...		

#### Note

① NA Certification. Request filed for UL and CSA.

## Technical Data and Specifications

### DS7 Soft Start Controllers

#### Rated Control Circuit

Voltage 24 Vac/Vdc  
Voltage 110/230 Vac  
Voltage 24 Vdc

Unit	DS7-340SX004N0-N DS7-342SX004N0-N DS7-34DSX004N0-D	DS7-340SX007N0-N DS7-342SX007N0-N DS7-34DSX007N0-D	DS7-340SX009N0-N DS7-342SX009N0-N DS7-34DSX009N0-D	DS7-340SX012N0-N DS7-342SX012N0-N DS7-34DSX012N0-D
------	--	--	--	--

#### General

Standards		IEC/EN 60947-4-2; GB14048.6; UL508; CSA-C22.2 No 0-M91; CSA-C22.2 No 14-05 CE marking	IEC/EN 60947-4-2; GB14048.6; UL508; CSA-C22.2 No 0-M91; CSA-C22.2 No 14-05 CE marking	IEC/EN 60947-4-2; GB14048.6; UL508; CSA-C22.2 No 0-M91; CSA-C22.2 No 14-05 CE marking	IEC/EN 60947-4-2; GB14048.6; UL508; CSA-C22.2 No 0-M91; CSA-C22.2 No 14-05 CE marking
Certifications/markings		UL/CE/CSA/C-Tick	UL/CE/CSA/C-Tick	UL/CE/CSA/C-Tick	UL/CE/CSA/C-Tick
Ambient temperature (operation)	°C	0 to 40 °C, above 40 °C de-rate linearly by 1% of rated current per Celsius to 60 °C -40 to +40 °C for low temperature version	0 to 40 °C, above 40 °C de-rate linearly by 1% of rated current per Celsius to 60 °C -40 to +40 °C for low temperature version	0 to 40 °C, above 40 °C de-rate linearly by 1% of rated current per Celsius to 60 °C -40 to +40 °C for low temperature version	0 to 40 °C, above 40 °C de-rate linearly by 1% of rated current per Celsius to 60 °C -40 to +40 °C for low temperature version
Ambient temperature (storage)	°C	-25 to 55 °C	-25 to 55 °C	-25 to 55 °C	-25 to 55 °C
Altitude		0–1000m, above 1000m de-rate linearly by 2.5% of rated current per 100m to a maximum of 2000m	0–1000m, above 1000m de-rate linearly by 2.5% of rated current per 100m to a maximum of 2000m	0–1000m, above 1000m de-rate linearly by 2.5% of rated current per 100m to a maximum of 2000m	0–1000m, above 1000m de-rate linearly by 2.5% of rated current per 100m to a maximum of 2000m
Installation		Vertical	Vertical	Vertical	Vertical
Protection class		IP20	IP20	IP20	IP20
Protection class applies to the front and operator control and display elements. Protection type from all sides is IP00.		With optional covers from the NZM range, protection type IP40 from all sides can be achieved	With optional covers from the NZM range, protection type IP40 from all sides can be achieved	With optional covers from the NZM range, protection type IP40 from all sides can be achieved	With optional covers from the NZM range, protection type IP40 from all sides can be achieved
Busbar tag shroud		Back of hand and finger-proof (from front face)	Back of hand and finger-proof (from front face)	Back of hand and finger-proof (from front face)	Back of hand and finger-proof (from front face)
Overvoltage category/pollution degree		II/2	II/2	II/2	II/2
Shock resistance		8g/11ms	8g/11ms	8g/11ms	8g/11ms
Vibration resistance according to EN 60721-3-2		2M2	2M2	2M2	2M2
Mean heat dissipation at rated duty cycle	W	0.2	0.35	0.35	0.6
Radio interference		B	B	B	B
Dimensions (W x H x D)					
DS7-340... and DS7-342...	in (mm)	1.77 x 5.12 x 3.74 (45 x 130 x 95)	1.77 x 5.12 x 3.74 (45 x 130 x 95)	1.77 x 5.12 x 3.74 (45 x 130 x 95)	1.77 x 5.12 x 3.74 (45 x 130 x 95)
DS7-34D...	in (mm)	1.77 x 5.31 x 3.74 (45 x 135 x 95)	1.77 x 5.31 x 3.74 (45 x 135 x 95)	1.77 x 5.31 x 3.74 (45 x 135 x 95)	1.77 x 5.31 x 3.74 (45 x 135 x 95)
Weight					
DS7-340...	lb (kg)	0.77 (0.35)	0.77 (0.35)	0.77 (0.35)	0.77 (0.35)
DS7-342...	lb (kg)	0.88 (0.40)	0.88 (0.40)	0.88 (0.40)	0.88 (0.40)
DS7-34D...	lb (kg)	0.90 (0.41)	0.90 (0.41)	0.90 (0.41)	0.90 (0.41)
<b>Main Circuit</b>					
Rated operational voltage	V	230–460 Vac	230–460 Vac	230–460 Vac	230–460 Vac
Mains frequency	Hz	50/60 Hz	50/60 Hz	50/60 Hz	50/60 Hz
Rated operation current AC 53	I <sub>e</sub>	4	7	9	12
<b>Motor Power Ratings</b>					
200 V	hp	0.75	1.5	2	3
230 V	hp	0.75	2	2	5
480 V	hp	2	3	5	10
230 V	kW	0.75	1.5	2.2	3
400 V	kW	1.5	3	4	5.5
Overload cycle according to EN 60947-4-2		4A: AC53a; 3-5; 75-10	7A: AC53a; 3-5; 75-10	9A: AC53a; 3-5; 75-10	12A: AC53a; 3-5; 75-10

### DS7 Soft Start Controllers, continued

#### Rated Control Circuit

		DS7-340SX004N0-N DS7-342SX004N0-N DS7-34DSX004N0-D	DS7-340SX007N0-N DS7-342SX007N0-N DS7-34DSX007N0-D	DS7-340SX009N0-N DS7-342SX009N0-N DS7-34DSX009N0-D	DS7-340SX012N0-N DS7-342SX012N0-N DS7-34DSX012N0-D
Voltage 24 Vac/Vdc					
Voltage 110/230 Vac					
Voltage 24 Vdc	Unit				

#### Wire Specifications

Power terminals					
Single conductor—solid or stranded	AWG	18–10	18–10	18–10	18–10
Terminal torque	lb-in	11	11	11	11
Control signals					
Single conductor—solid or stranded	AWG	18–10	18–10	18–10	18–10
Terminal torque	lb-in	11	11	11	11

#### Power Section

Rated impulse withstand voltage	$U_{imp}$ 1.2/50 s	4 kV	4 kV	4 kV	4 kV
Rated insulation voltage		500	500	500	500

#### Control Commands—Vac/Vdc

Supply voltage control board $U_s$ nominal	Vac/Vdc	20.4–26.4	20.4–26.4	20.4–26.4	20.4–26.4
Current consumption at 24 Vac/Vdc	mA	1.6	1.6	1.6	1.6
Pick-up voltage		+17.3–+27	+17.3–+27	+17.3–+27	+17.3–+27
Drop-out voltage		+3–0	+3–0	+3–0	+3–0

#### Relay Outputs

Number of relays		1 (TOR)	1 (TOR)	1 (TOR)	1 (TOR)
Maximum voltage	Vac	250	250	250	250
Maximum current	A	1A	1A	1A	1A

#### Soft Start Functions

Ramp times					
Start ramp	s	1–30	1–30	1–30	1–30
Stop ramp	s	0–30	0–30	0–30	0–30
Initial voltage % line voltage					
DS7-342...		30–92%	30–92%	30–92%	30–92%
DS7-340...		30–100%	30–100%	30–100%	30–100%
DS7-34D...		30–92%	30–92%	30–92%	30–92%

#### Control Commands—Vac

Supply voltage control board $U_s$ nominal	Vac	102–253	102–253	102–253	102–253
Current consumption at 24 Vac/Vdc	mA	4	4	4	4
Pick-up voltage	Vac	102–230	102–230	102–230	102–230
Drop-out voltage	Vac	0–28	0–28	0–28	0–28

#### Relay Outputs

Number of relays		1 (TOR)	1 (TOR)	1 (TOR)	1 (TOR)
Maximum voltage	Vac	250	250	250	250
Maximum current	A	3A	3A	3A	3A

#### Soft Start Functions

Ramp times					
Start ramp	s	1–30	1–30	1–30	1–30
Stop ramp	s	0–30	0–30	0–30	0–30
Initial voltage % line voltage					
		30–92%	30–92%	30–92%	30–92%

## DS7 Soft Start Controllers, continued

## Rated Control Circuit

Voltage 24 Vac/Vdc  
Voltage 110/230 Vac  
Voltage 24 Vdc

Unit

DS7-340SX016N0-N  
DS7-342SX016N0-N  
DS7-34DSX016N0-D

DS7-340SX024N0-N  
DS7-342SX024N0-N  
DS7-34DSX024N0-D

DS7-340SX032N0-N  
DS7-342SX032N0-N  
DS7-34DSX032N0-D

## General

Standards		IEC/EN 60947-4-2; GB14048.6; UL508; CSA-C22.2 No 0-M91; CSA-C22.2 No 14-05 CE marking	IEC/EN 60947-4-2; GB14048.6; UL508; CSA-C22.2 No 0-M91; CSA-C22.2 No 14-05 CE marking	IEC/EN 60947-4-2; GB14048.6; UL508; CSA-C22.2 No 0-M91; CSA-C22.2 No 14-05 CE marking
Certifications/markings		UL/CE/CSA/C-Tick	UL/CE/CSA/C-Tick	UL/CE/CSA/C-Tick
Ambient temperature (operation)	°C	0 to 40 °C, above 40 °C de-rate linearly by 1% of rated current per Celsius to 60 °C –40 to +40 °C for low temperature version	0 to 40 °C, above 40 °C de-rate linearly by 1% of rated current per Celsius to 60 °C –40 to +40 °C for low temperature version	0 to 40 °C, above 40 °C de-rate linearly by 1% of rated current per Celsius to 60 °C –40 to +40 °C for low temperature version
Ambient temperature (storage)	°C	–25 to 55 °C	–25 to 55 °C	–25 to 55 °C
Altitude		0–1000m, above 1000m de-rate linearly by 2.5% of rated current per 100m to a maximum of 2000m	0–1000m, above 1000m de-rate linearly by 2.5% of rated current per 100m to a maximum of 2000m	0–1000m, above 1000m de-rate linearly by 2.5% of rated current per 100m to a maximum of 2000m
Installation		Vertical	Vertical	Vertical
Protection class		IP20	IP20	IP20
Protection class applies to the front and operator control and display elements. Protection type from all sides is IP00.		With optional covers from the NZM range, protection type IP40 from all sides can be achieved	With optional covers from the NZM range, protection type IP40 from all sides can be achieved	With optional covers from the NZM range, protection type IP40 from all sides can be achieved
Busbar tag shroud		Back of hand and finger-proof (from front face)	Back of hand and finger-proof (from front face)	Back of hand and finger-proof (from front face)
Overvoltage category/ pollution degree		II/2	II/2	II/2
Shock resistance		8g/11ms	8g/11ms	8g/11ms
Vibration resistance according to EN 60721-3-2		2M2	2M2	2M2
Mean heat dissipation at rated duty cycle	W	0.8	1.1	1.5
Radio interference		B	B	B
Dimensions (W x H x D)				
DS7-340... and DS7-342...	in (mm)	1.77 x 5.91 x 4.65 (45 x 150 x 118)	1.77 x 5.91 x 4.65 (45 x 150 x 118)	1.77 x 5.91 x 4.65 (45 x 150 x 118)
DS7-34D...	in (mm)	1.77 x 5.91 x 4.65 (45 x 150 x 118)	1.77 x 5.91 x 4.65 (45 x 150 x 118)	1.77 x 5.91 x 4.65 (45 x 150 x 118)
Weight				
DS7-340...	lb (kg)	0.88 (0.40)	0.88 (0.40)	0.88 (0.40)
DS7-342...	lb (kg)	0.99 (0.45)	0.99 (0.45)	0.99 (0.45)
DS7-34D...	lb (kg)	0.90 (0.41)	0.90 (0.41)	0.90 (0.41)
<b>Main Circuit</b>				
Rated operational voltage	V	230–460 Vac	230–460 Vac	230–460 Vac
Mains frequency	Hz	50/60 Hz	50/60 Hz	50/60 Hz
Rated operation current AC 53	I <sub>e</sub>	16	24	32
<b>Motor Power Ratings</b>				
200 V	hp	3	5	10
230 V	hp	5	7.5	10
480 V	hp	10	15	25
230 V	kW	4	5.5	7.5
400 V	kW	7.5	11	15
Overload cycle according to EN 60947-4-2		16A: AC53a; 3-5; 75-10	24A: AC53a; 3-5; 75-10	32A: AC53a; 3-5; 75-10

### DS7 Soft Start Controllers, continued

#### Rated Control Circuit

Voltage 24 Vac/Vdc  
Voltage 110/230 Vac  
Voltage 24 Vdc

Unit	DS7-340SX016N0-N DS7-342SX016N0-N DS7-34DSX016N0-D	DS7-340SX024N0-N DS7-342SX024N0-N DS7-34DSX024N0-D	DS7-340SX032N0-N DS7-342SX032N0-N DS7-34DSX032N0-D
------	--	--	--

#### Wire Specifications

##### Power terminals

Single conductor—solid or stranded	AWG	18–6	18–6	18–6
Terminal torque	lb-in	11	11	11

##### Control Signals

Single conductor—solid or stranded	AWG	18–10	18–10	18–10
Terminal torque	lb-in	11	11	11

#### Power Section

Rated impulse withstand voltage	$U_{imp}$ 1.2/50 s	4 kV	4 kV	4 kV
Rated insulation voltage		500	500	500

#### Control Commands—Vac/Vdc

Supply voltage control board $U_s$ nominal	Vac/Vdc	20.4–26.4	20.4–26.4	20.4–26.4
Current consumption at 24 Vac/Vdc	mA	1.6	1.6	1.6
Pick-up voltage		+17.3–+27	+17.3–+27	+17.3–+27
Drop-out voltage		+3–0	+3–0	+3–0

#### Relay Outputs

Number of relays		2 (TOR, Ready)	2 (TOR, Ready)	2 (TOR, Ready)
Maximum voltage	Vac	250	250	250
Maximum current	A	1A	1A	1A

#### Soft Start Functions

Ramp times				
Start ramp	s	1–30	1–30	1–30
Stop ramp	s	0–30	0–30	0–30
Initial voltage % line voltage				
DS7-342...		30–92%	30–92%	30–92%
DS7-340...		30–100%	30–100%	30–100%
DS7-34D...		30–92%	30–92%	30–92%

#### Control Commands—Vac

Supply voltage control board $U_s$ nominal	Vac	102–253	102–253	102–253
Current consumption at 102–253 Vac	mA	4	4	4
Pick-up voltage	Vac	102–230	102–230	102–230
Drop-out voltage	Vac	0–28	0–28	0–28

#### Relay Outputs

Number of relays		2 (TOR, Run)	2 (TOR, Run)	2 (TOR, Run)
Maximum voltage	Vac	250	250	250
Maximum current	A	3A	3A	3A

#### Soft Start Functions

Ramp times				
Start ramp	s	1–30	1–30	1–30
Stop ramp	s	0–30	0–30	0–30
Initial voltage % line voltage				
		30–92%	30–92%	30–92%

## DS7 Soft Start Controllers, continued

## Rated Control Circuit

Voltage 24 Vac/Vdc Voltage 110/230 Vac Voltage 24 Vdc	Unit	DS7-340SX100N0-N DS7-342SX100N0-N DS7-34DSX100N0-D	DS7-340SX135N0-N DS7-342SX135N0-N DS7-34DSX135N0-D	DS7-340SX160N0-N DS7-342SX160N0-N DS7-34DSX160N0-D	DS7-340SX200N0-N DS7-342SX200N0-N DS7-34DSX200N0-D
---	------	--	--	--	--

## General

Standards		IEC/EN 60947-4-2; GB14048.6; UL508; CSA-C22.2 No 0-M91; CSA-C22.2 No 14-05 CE marking	IEC/EN 60947-4-2; GB14048.6; UL508; CSA-C22.2 No 0-M91; CSA-C22.2 No 14-05 CE marking	IEC/EN 60947-4-2; GB14048.6; UL508; CSA-C22.2 No 0-M91; CSA-C22.2 No 14-05 CE marking	IEC/EN 60947-4-2; GB14048.6; UL508; CSA-C22.2 No 0-M91; CSA-C22.2 No 14-05 CE marking
Certifications/markings		UL/CE/CSA/C-Tick	UL/CE/CSA/C-Tick	UL/CE/CSA/C-Tick	UL/CE/CSA/C-Tick
Ambient temperature (operation)	°C	0 to 40 °C, above 40 °C de-rate linearly by 1% of rated current per Celsius to 60 °C –40 to +40 °C for low temperature version	0 to 40 °C, above 40 °C de-rate linearly by 1% of rated current per Celsius to 60 °C –40 to +40 °C for low temperature version	0 to 40 °C, above 40 °C de-rate linearly by 1% of rated current per Celsius to 60 °C –40 to +40 °C for low temperature version	0 to 40 °C, above 40 °C de-rate linearly by 1% of rated current per Celsius to 60 °C –40 to +40 °C for low temperature version
Ambient temperature (storage)	°C	–25 to 55 °C	–25 to 55 °C	–25 to 55 °C	–25 to 55 °C
Altitude		0–1000m, above 1000m de-rate linearly by 2.5% of rated current per 100m to a maximum of 2000m	0–1000m, above 1000m de-rate linearly by 2.5% of rated current per 100m to a maximum of 2000m	0–1000m, above 1000m de-rate linearly by 2.5% of rated current per 100m to a maximum of 2000m	0–1000m, above 1000m de-rate linearly by 2.5% of rated current per 100m to a maximum of 2000m
Installation		Vertical	Vertical	Vertical	Vertical
Protection class		IP20	IP20	IP20	IP20
Protection class applies to the front and operator control and display elements. Protection type from all sides is IP00.		With optional covers from the NZM range, protection type IP40 from all sides can be achieved	With optional covers from the NZM range, protection type IP40 from all sides can be achieved	With optional covers from the NZM range, protection type IP40 from all sides can be achieved	With optional covers from the NZM range, protection type IP40 from all sides can be achieved
Busbar tag shroud		Back of hand and finger-proof (from front face)	Back of hand and finger-proof (from front face)	Back of hand and finger-proof (from front face)	Back of hand and finger-proof (from front face)
Overvoltage category/ pollution degree		II/2	II/2	II/2	II/2
Shock resistance		8g/11ms	8g/11ms	8g/11ms	8g/11ms
Vibration resistance according to EN 60721-3-2		2M2	2M2	2M2	2M2
Mean heat dissipation at rated duty cycle	W	25	24	30	42
Radio interference		B	B	B	B
Dimensions (W x H x D)					
DS7-340... DS7-342... and DS7-34D...	in (mm)	3.66 x 6.89 x 5.47 (93 x 175 x 139)	4.25 x 8.46 x 7.01 (108 x 215 x 178)	4.25 x 8.46 x 7.01 (108 x 215 x 178)	4.25 x 8.46 x 7.01 (108 x 215 x 178)
Weight					
DS7-340... DS7-342... and DS7-34D...	lb (kg)	3.97 (1.8)	8.16 (3.7)	8.16 (3.7)	8.16 (3.7)
<b>Main Circuit</b>					
Rated operational voltage	V	230–460 Vac	230–460 Vac	230–460 Vac	230–460 Vac
Mains frequency	Hz	50/60 Hz	50/60 Hz	50/60 Hz	50/60 Hz
Rated operation current AC 53	I <sub>e</sub>	100	135	160	200
<b>Motor Power Ratings</b>					
200 V	hp	30	40	50	60
230 V	hp	30	50	60	75
480 V	hp	75	100	125	150
230 V	kW	30	30	45	55
400 V	kW	55	75	90	110
Overload cycle according to EN 60947-4-2		100A: AC53a; 3-5; 75-10	135A: AC53a; 3-5; 75-10	160A: AC53a; 3-5; 75-10	200A: AC53a; 3-5; 75-10

### DS7 Soft Start Controllers, continued

#### Rated Control Circuit

Unit	DS7-340SX100N0-N DS7-342SX100N0-N DS7-34DSX100N0-D	DS7-340SX135N0-N DS7-342SX135N0-N DS7-34DSX135N0-D	DS7-340SX160N0-N DS7-342SX160N0-N DS7-34DSX160N0-D	DS7-340SX200N0-N DS7-342SX200N0-N DS7-34DSX200N0-D
------	--	--	--	--

#### Wire Specifications

Power terminals					
Single conductor—solid or stranded	AWG	12–2/0	12–350 kcmil	12–350 kcmil	12–350 kcmil
Terminal torque	lb-in	53–80	44–123	44–123	44–123
Control signals					
Single conductor—solid or stranded	AWG	18–10	18–10	18–10	18–10
Terminal torque	lb-in	11	11	11	11

#### Power Section

Rated impulse withstand voltage	$U_{imp}$ 1.2/50 s	4 kV	4 kV	4 kV	4 kV
Rated insulation voltage		500	500	500	500

#### Control Commands—24 Vac/Vdc

Supply voltage control board $U_s$ nominal	Vac/Vdc	20.4–26.4	20.4–26.4	20.4–26.4	20.4–26.4
Current consumption at 24 Vac/Vdc	mA	65	65	65	65
Pick-up voltage		+17.3–+27	+17.3–+27	+17.3–+27	+17.3–+27
Drop-out voltage		+3–0	+3–0	+3–0	+3–0

#### Relay Outputs

Number of relays		2 (TOR)	2 (TOR)	2 (TOR)	2 (TOR)
Maximum voltage	Vac	250	250	250	250
Maximum current	A	1A	1A	1A	1A

#### Soft Start Functions

Ramp times					
Start ramp	s	1–30	1–30	1–30	1–30
Stop ramp	s	0–30	0–30	0–30	0–30
Initial voltage % line voltage					
DS7-342...		30–92%	30–92%	30–92%	30–92%
DS7-340...		30–100%	30–100%	30–100%	30–100%
DS7-34D...		30–92%	30–92%	30–92%	30–92%

#### Control Commands—110–230 Vac

Supply voltage control board $U_s$ nominal	Vac	102–253	102–253	102–253	102–253
Current consumption at 24 Vac/Vdc	mA	14	14	14	14
Pick-up voltage	Vac	102–230	102–230	102–230	102–230
Drop-out voltage	Vac	0–28	0–28	0–28	0–28

#### Relay Outputs

Number of relays		2 (TOR)	2 (TOR)	2 (TOR)	2 (TOR)
Maximum voltage	Vac	250	250	250	250
Maximum current	A	3A	3A	3A	3A

#### Soft Start Functions

Ramp times					
Start ramp	s	1–30	1–30	1–30	1–30
Stop ramp	s	0–30	0–30	0–30	0–30
Initial voltage % line voltage		30–92%	30–92%	30–92%	30–92%



# 1.1

## Reduced Voltage Motor Starters

### Solid-State Controllers

1

#### Dimensions

Approximate Dimensions in Inches (mm)

##### Frame 1

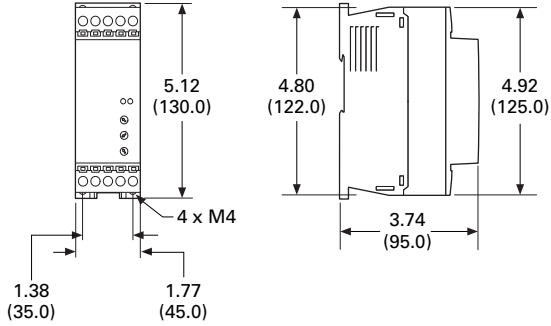

##### Catalog Numbers

DS7-340SX004N0-N	DS7-342SX004N0-N
DS7-340SX007N0-N	DS7-342SX007N0-N
DS7-340SX009N0-N	DS7-342SX009N0-N
DS7-340SX012N0-N	DS7-342SX012N0-N

##### Frame 2

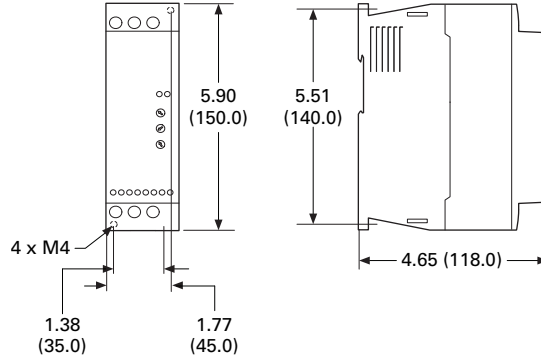

##### Catalog Numbers

DS7-340SX016N0-N	DS7-342SX016N0-N
DS7-340SX024N0-N	DS7-342SX024N0-N
DS7-340SX032N0-N	DS7-342SX032N0-N

##### Frame 1—SmartWire-DT

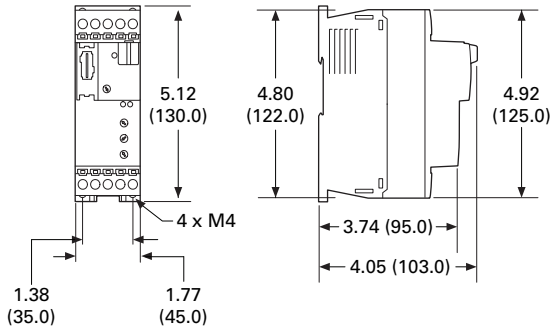

##### Catalog Numbers

DS7-34DSX004N0-D	DS7-34DSX009N0-D
DS7-34DSX007N0-D	DS7-34DSX012N0-D

##### Frame 2—SmartWire-DT

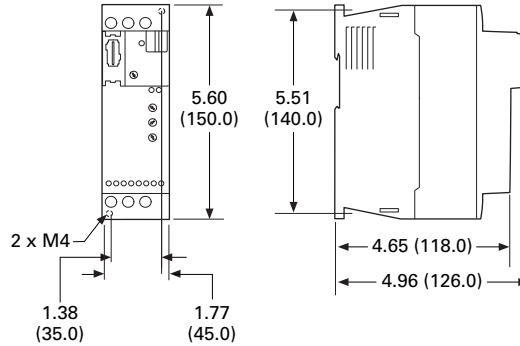

##### Catalog Numbers

DS7-34DSX016N0-D
DS7-34DSX024N0-D
DS7-34DSX032N0-D

### Frame 3—SmartWire-DT and Standard (Non SmartWire-DT)

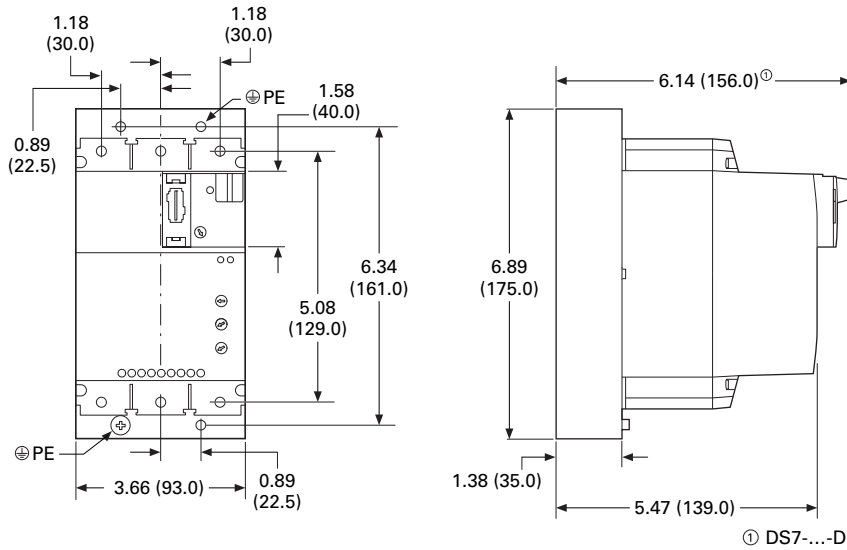

#### Catalog Numbers

DS7-340SX041N0-N	DS7-342SX041N0-N	DS7-34DSX041N0-D
DS7-340SX055N0-N	DS7-342SX055N0-N	DS7-34DSX055N0-D
DS7-340SX070N0-N	DS7-342SX070N0-N	DS7-34DSX070N0-D
DS7-340SX081N0-N	DS7-342SX081N0-N	DS7-34DSX081N0-D
DS7-340SX100N0-N	DS7-342SX100N0-N	DS7-34DSX100N0-D

### Frame 4—SmartWire-DT and Standard (Non SmartWire-DT)

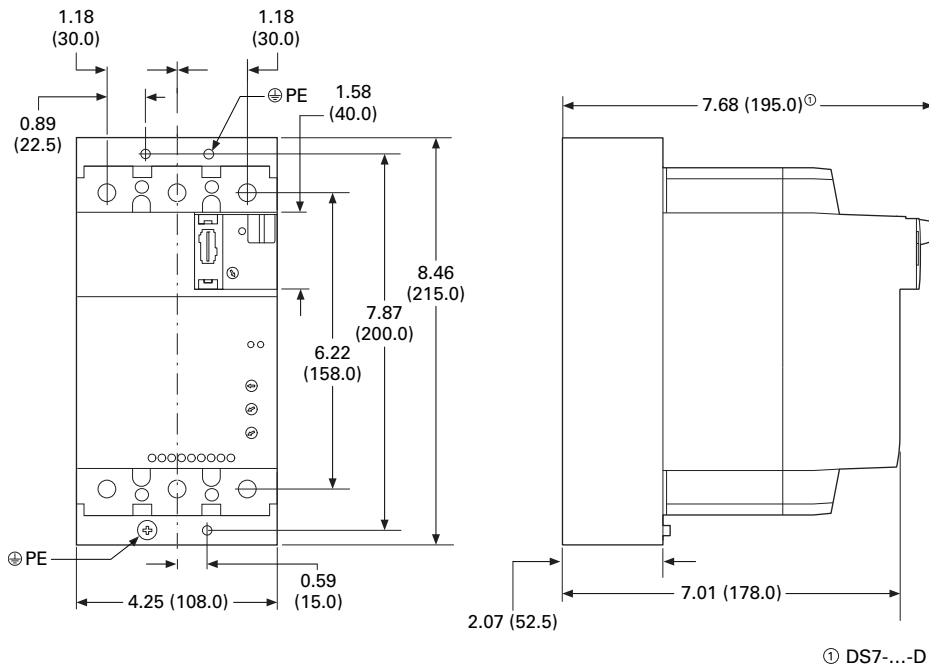

#### Catalog Numbers

DS7-342SX135N0-N	DS7-340SX135N0-N	DS7-34DSX135N0-D
DS7-342SX160N0-N	DS7-340SX160N0-N	DS7-34DSX160N0-D
DS7-342SX200N0-N	DS7-340SX200N0-N	DS7-34DSX200N0-D

## DS7 Soft Start Controllers, continued

## Rated Control Circuit

Voltage 24 Vac/Vdc Voltage 110/230 Vac Voltage 24 Vdc	Unit	DS7-340SX041N0-N DS7-342SX041N0-N DS7-34DSX041N0-D	DS7-340SX055N0-N DS7-342SX055N0-N DS7-34DSX055N0-D	DS7-340SX070N0-N DS7-342SX070N0-N DS7-34DSX070N0-D	DS7-340SX081N0-N DS7-342SX081N0-N DS7-34DSX081N0-D
---	------	--	--	--	--

## General

Standards		IEC/EN 60947-4-2; GB14048.6; UL508; CSA-C22.2 No 0-M91; CSA-C22.2 No 14-05 CE marking	IEC/EN 60947-4-2; GB14048.6; UL508; CSA-C22.2 No 0-M91; CSA-C22.2 No 14-05 CE marking	IEC/EN 60947-4-2; GB14048.6; UL508; CSA-C22.2 No 0-M91; CSA-C22.2 No 14-05 CE marking	IEC/EN 60947-4-2; GB14048.6; UL508; CSA-C22.2 No 0-M91; CSA-C22.2 No 14-05 CE marking
Certifications/markings		UL/CE/CSA/C-Tick	UL/CE/CSA/C-Tick	UL/CE/CSA/C-Tick	UL/CE/CSA/C-Tick
Ambient temperature (operation)	°C	0 to 40 °C, above 40 °C de-rate linearly by 1% of rated current per Celsius to 60 °C –40 to +40 °C for low temperature version	0 to 40 °C, above 40 °C de-rate linearly by 1% of rated current per Celsius to 60 °C –40 to +40 °C for low temperature version	0 to 40 °C, above 40 °C de-rate linearly by 1% of rated current per Celsius to 60 °C –40 to +40 °C for low temperature version	0 to 40 °C, above 40 °C de-rate linearly by 1% of rated current per Celsius to 60 °C –40 to +40 °C for low temperature version
Ambient temperature (storage)	°C	–25 to 55 °C	–25 to 55 °C	–25 to 55 °C	–25 to 55 °C
Altitude		0–1000m, above 1000m de-rate linearly by 2.5% of rated current per 100m to a maximum of 2000m	0–1000m, above 1000m de-rate linearly by 2.5% of rated current per 100m to a maximum of 2000m	0–1000m, above 1000m de-rate linearly by 2.5% of rated current per 100m to a maximum of 2000m	0–1000m, above 1000m de-rate linearly by 2.5% of rated current per 100m to a maximum of 2000m
Installation		Vertical	Vertical	Vertical	Vertical
Protection class		IP20	IP20	IP20	IP20
Protection class applies to the front and operator control and display elements. Protection type from all sides is IP00.		With optional covers from the NZM range, protection type IP40 from all sides can be achieved	With optional covers from the NZM range, protection type IP40 from all sides can be achieved	With optional covers from the NZM range, protection type IP40 from all sides can be achieved	With optional covers from the NZM range, protection type IP40 from all sides can be achieved
Busbar tag shroud		Back of hand and finger-proof (from front face)	Back of hand and finger-proof (from front face)	Back of hand and finger-proof (from front face)	Back of hand and finger-proof (from front face)
Overvoltage category/ pollution degree		II/2	II/2	II/2	II/2
Shock resistance		8g/11ms	8g/11ms	8g/11ms	8g/11ms
Vibration resistance according to EN 60721-3-2		2M2	2M2	2M2	2M2
Mean heat dissipation at rated duty cycle	W	7	10	13	18
Radio interference		B	B	B	B
Dimensions (W x H x D)					
DS7-340... DS7-342... and DS7-34D...	in (mm)	3.66 x 6.89 x 5.47 (93 x 175 x 139)	3.66 x 6.89 x 5.47 (93 x 175 x 139)	3.66 x 6.89 x 5.47 (93 x 175 x 139)	3.66 x 6.89 x 5.47 (93 x 175 x 139)
Weight					
DS7-340... DS7-342... and DS7-34D...	lb (kg)	3.97 (1.8)	3.97 (1.8)	3.97 (1.8)	3.97 (1.8)
<b>Main Circuit</b>					
Rated operational voltage	V	230–460 Vac	230–460 Vac	230–460 Vac	230–460 Vac
Mains frequency	Hz	50/60 Hz	50/60 Hz	50/60 Hz	50/60 Hz
Rated operation current AC 53	I <sub>e</sub>	41	55	70	81
<b>Motor Power Ratings</b>					
200 V	hp	10	15	20	25
230 V	hp	10	20	25	30
480 V	hp	30	40	50	60
230 V	kW	11	15	15	22
400 V	kW	22	30	37	45
Overload cycle according to EN 60947-4-2		41A: AC53a; 3-5; 75-10	55A: AC53a; 3-5; 75-10	70A: AC53a; 3-5; 75-10	81A: AC53a; 3-5; 75-10

### DS7 Soft Start Controllers, continued

#### Rated Control Circuit

Voltage 24 Vac/Vdc Voltage 110/230 Vac Voltage 24 Vdc	Unit	DS7-340SX041N0-N DS7-342SX041N0-N DS7-34DSX041N0-D	DS7-340SX055N0-N DS7-342SX055N0-N DS7-34DSX055N0-D	DS7-340SX070N0-N DS7-342SX070N0-N DS7-34DSX070N0-D	DS7-340SX081N0-N DS7-342SX081N0-N DS7-34DSX081N0-D
---	------	--	--	--	--

#### Wire Specifications

Power terminals					
Single conductor—solid or stranded	AWG	12–2/0	12–2/0	12–2/0	12–2/0
Terminal torque	lb-in	53–80	53–80	53–80	53–80
Control signals					
Single conductor—solid or stranded	AWG	18–10	18–10	18–10	18–10
Terminal torque	lb-in	11	11	11	11

#### Power Section

Rated impulse withstand voltage	$U_{imp}$ 1.2/50 s	4 kV	4 kV	4 kV	4 kV
Rated insulation voltage		500	500	500	500

#### Control Commands—24 Vac/Vdc

Supply voltage control board $U_s$ nominal	Vac/Vdc	20.4–26.4	20.4–26.4	20.4–26.4	20.4–26.4
Current consumption at 24 Vac/Vdc	mA	65	65	65	65
Pick-up voltage		+17.3–+27	+17.3–+27	+17.3–+27	+17.3–+27
Drop-out voltage		+3–0	+3–0	+3–0	+3–0

#### Relay Outputs

Number of relays		2 (TOR)	2 (TOR)	2 (TOR)	2 (TOR)
Maximum voltage	Vac	250	250	250	250
Maximum current	A	1A	1A	1A	1A

#### Soft Start Functions

Ramp times					
Start ramp	s	1–30	1–30	1–30	1–30
Stop ramp	s	0–30	0–30	0–30	0–30
Initial voltage % line voltage					
DS7-342...		30–92%	30–92%	30–92%	30–92%
DS7-340...		30–100%	30–100%	30–100%	30–100%
DS7-34D...		30–92%	30–92%	30–92%	30–92%

#### Control Commands—110–230 Vac

Supply voltage control board $U_s$ nominal	Vac	102–253	102–253	102–253	102–253
Current consumption at 24 Vac/Vdc	mA	14	14	14	14
Pick-up voltage	Vac	102–230	102–230	102–230	102–230
Drop-out voltage	Vac	0–28	0–28	0–28	0–28

#### Relay Outputs

Number of relays		2 (TOR)	2 (TOR)	2 (TOR)	2 (TOR)
Maximum voltage	Vac	250	250	250	250
Maximum current	A	3A	3A	3A	3A

#### Soft Start Functions

Ramp times					
Start ramp	s	1–30	1–30	1–30	1–30
Stop ramp	s	0–30	0–30	0–30	0–30
Initial voltage % line voltage		30–92%	30–92%	30–92%	30–92%

## DS7 Soft Start Controllers, continued

## Rated Control Circuit

Voltage 24 Vac/Vdc Voltage 110/230 Vac Voltage 24 Vdc	Unit	DS7-340SX100N0-N DS7-342SX100N0-N DS7-34DSX100N0-D	DS7-340SX135N0-N DS7-342SX135N0-N DS7-34DSX135N0-D	DS7-340SX160N0-N DS7-342SX160N0-N DS7-34DSX160N0-D	DS7-340SX200N0-N DS7-342SX200N0-N DS7-34DSX200N0-D
---	------	--	--	--	--

## General

Standards		IEC/EN 60947-4-2; GB14048.6; UL508; CSA-C22.2 No 0-M91; CSA-C22.2 No 14-05 CE marking	IEC/EN 60947-4-2; GB14048.6; UL508; CSA-C22.2 No 0-M91; CSA-C22.2 No 14-05 CE marking	IEC/EN 60947-4-2; GB14048.6; UL508; CSA-C22.2 No 0-M91; CSA-C22.2 No 14-05 CE marking	IEC/EN 60947-4-2; GB14048.6; UL508; CSA-C22.2 No 0-M91; CSA-C22.2 No 14-05 CE marking
Certifications/markings		UL/CE/CSA/C-Tick	UL/CE/CSA/C-Tick	UL/CE/CSA/C-Tick	UL/CE/CSA/C-Tick
Ambient temperature (operation)	°C	0 to 40 °C, above 40 °C de-rate linearly by 1% of rated current per Celsius to 60 °C –40 to +40 °C for low temperature version	0 to 40 °C, above 40 °C de-rate linearly by 1% of rated current per Celsius to 60 °C –40 to +40 °C for low temperature version	0 to 40 °C, above 40 °C de-rate linearly by 1% of rated current per Celsius to 60 °C –40 to +40 °C for low temperature version	0 to 40 °C, above 40 °C de-rate linearly by 1% of rated current per Celsius to 60 °C –40 to +40 °C for low temperature version
Ambient temperature (storage)	°C	–25 to 55 °C	–25 to 55 °C	–25 to 55 °C	–25 to 55 °C
Altitude		0–1000m, above 1000m de-rate linearly by 2.5% of rated current per 100m to a maximum of 2000m	0–1000m, above 1000m de-rate linearly by 2.5% of rated current per 100m to a maximum of 2000m	0–1000m, above 1000m de-rate linearly by 2.5% of rated current per 100m to a maximum of 2000m	0–1000m, above 1000m de-rate linearly by 2.5% of rated current per 100m to a maximum of 2000m
Installation		Vertical	Vertical	Vertical	Vertical
Protection class		IP20	IP20	IP20	IP20
Protection class applies to the front and operator control and display elements. Protection type from all sides is IP00.		With optional covers from the NZM range, protection type IP40 from all sides can be achieved	With optional covers from the NZM range, protection type IP40 from all sides can be achieved	With optional covers from the NZM range, protection type IP40 from all sides can be achieved	With optional covers from the NZM range, protection type IP40 from all sides can be achieved
Busbar tag shroud		Back of hand and finger-proof (from front face)	Back of hand and finger-proof (from front face)	Back of hand and finger-proof (from front face)	Back of hand and finger-proof (from front face)
Overvoltage category/ pollution degree		II/2	II/2	II/2	II/2
Shock resistance		8g/11ms	8g/11ms	8g/11ms	8g/11ms
Vibration resistance according to EN 60721-3-2		2M2	2M2	2M2	2M2
Mean heat dissipation at rated duty cycle	W	25	24	30	42
Radio interference		B	B	B	B
Dimensions (W x H x D)					
DS7-340... DS7-342... and DS7-34D...	in (mm)	3.66 x 6.89 x 5.47 (93 x 175 x 139)	4.25 x 8.46 x 7.01 (108 x 215 x 178)	4.25 x 8.46 x 7.01 (108 x 215 x 178)	4.25 x 8.46 x 7.01 (108 x 215 x 178)
Weight					
DS7-340... DS7-342... and DS7-34D...	lb (kg)	3.97 (1.8)	8.16 (3.7)	8.16 (3.7)	8.16 (3.7)
<b>Main Circuit</b>					
Rated operational voltage	V	230–460 Vac	230–460 Vac	230–460 Vac	230–460 Vac
Mains frequency	Hz	50/60 Hz	50/60 Hz	50/60 Hz	50/60 Hz
Rated operation current AC 53	I <sub>e</sub>	100	135	160	200
<b>Motor Power Ratings</b>					
200 V	hp	30	40	50	60
230 V	hp	30	50	60	75
480 V	hp	75	100	125	150
230 V	kW	30	30	45	55
400 V	kW	55	75	90	110
Overload cycle according to EN 60947-4-2		100A: AC53a; 3-5; 75-10	135A: AC53a; 3-5; 75-10	160A: AC53a; 3-5; 75-10	200A: AC53a; 3-5; 75-10

### DS7 Soft Start Controllers, continued

#### Rated Control Circuit

		DS7-340SX100N0-N DS7-342SX100N0-N DS7-34DSX100N0-D	DS7-340SX135N0-N DS7-342SX135N0-N DS7-34DSX135N0-D	DS7-340SX160N0-N DS7-342SX160N0-N DS7-34DSX160N0-D	DS7-340SX200N0-N DS7-342SX200N0-N DS7-34DSX200N0-D
Voltage 24 Vac/Vdc	Unit				
Voltage 110/230 Vac					
Voltage 24 Vdc					

#### Wire Specifications

Power terminals					
Single conductor—solid or stranded	AWG	12–2/0	12–350 kcmil	12–350 kcmil	12–350 kcmil
Terminal torque	lb-in	53–80	44–123	44–123	44–123
Control signals					
Single conductor—solid or stranded	AWG	18–10	18–10	18–10	18–10
Terminal torque	lb-in	11	11	11	11

#### Power Section

Rated impulse withstand voltage	$U_{imp}$ 1.2/50 s	4 kV	4 kV	4 kV	4 kV
Rated insulation voltage		500	500	500	500

#### Control Commands—24 Vac/Vdc

Supply voltage control board $U_s$ nominal	Vac/Vdc	20.4–26.4	20.4–26.4	20.4–26.4	20.4–26.4
Current consumption at 24 Vac/Vdc	mA	65	65	65	65
Pick-up voltage		+17.3–+27	+17.3–+27	+17.3–+27	+17.3–+27
Drop-out voltage		+3–0	+3–0	+3–0	+3–0

#### Relay Outputs

Number of relays		2 (TOR)	2 (TOR)	2 (TOR)	2 (TOR)
Maximum voltage	Vac	250	250	250	250
Maximum current	A	1A	1A	1A	1A

#### Soft Start Functions

Ramp times					
Start ramp	s	1–30	1–30	1–30	1–30
Stop ramp	s	0–30	0–30	0–30	0–30
Initial voltage % line voltage					
DS7-342...		30–92%	30–92%	30–92%	30–92%
DS7-340...		30–100%	30–100%	30–100%	30–100%
DS7-34D...		30–92%	30–92%	30–92%	30–92%

#### Control Commands—110–230 Vac

Supply voltage control board $U_s$ nominal	Vac	102–253	102–253	102–253	102–253
Current consumption at 24 Vac/Vdc	mA	14	14	14	14
Pick-up voltage	Vac	102–230	102–230	102–230	102–230
Drop-out voltage	Vac	0–28	0–28	0–28	0–28

#### Relay Outputs

Number of relays		2 (TOR)	2 (TOR)	2 (TOR)	2 (TOR)
Maximum voltage	Vac	250	250	250	250
Maximum current	A	3A	3A	3A	3A

#### Soft Start Functions

Ramp times					
Start ramp	s	1–30	1–30	1–30	1–30
Stop ramp	s	0–30	0–30	0–30	0–30
Initial voltage % line voltage					
		30–92%	30–92%	30–92%	30–92%

# 1.1

## Reduced Voltage Motor Starters

### Solid-State Controllers

1

#### Dimensions

Approximate Dimensions in Inches (mm)

##### Frame 1

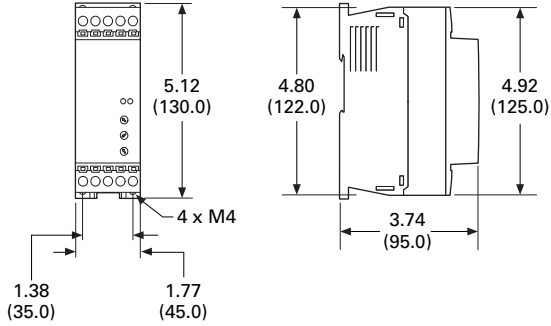

##### Catalog Numbers

DS7-340SX004N0-N	DS7-342SX004N0-N
DS7-340SX007N0-N	DS7-342SX007N0-N
DS7-340SX009N0-N	DS7-342SX009N0-N
DS7-340SX012N0-N	DS7-342SX012N0-N

##### Frame 2

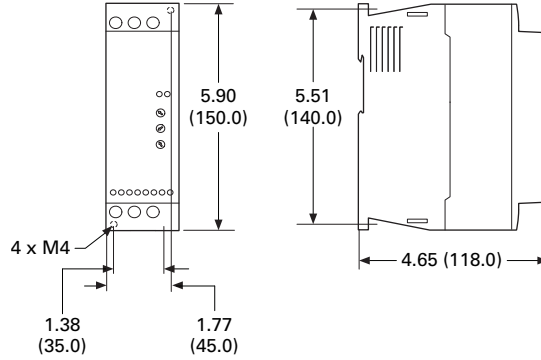

##### Catalog Numbers

DS7-340SX016N0-N	DS7-342SX016N0-N
DS7-340SX024N0-N	DS7-342SX024N0-N
DS7-340SX032N0-N	DS7-342SX032N0-N

##### Frame 1—SmartWire-DT

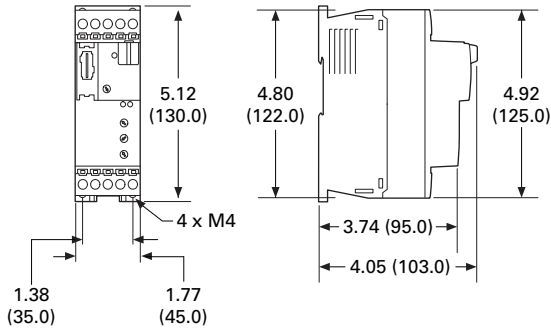

##### Catalog Numbers

DS7-34DSX004N0-D	DS7-34DSX009N0-D
DS7-34DSX007N0-D	DS7-34DSX012N0-D

##### Frame 2—SmartWire-DT

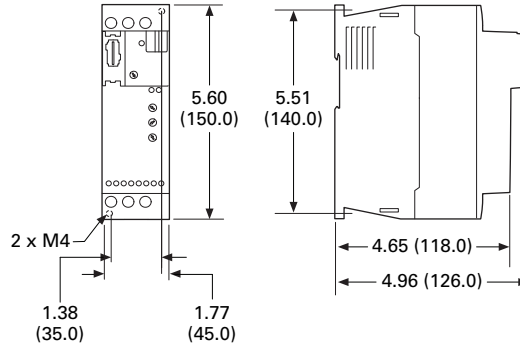

##### Catalog Numbers

DS7-34DSX016N0-D
DS7-34DSX024N0-D
DS7-34DSX032N0-D

### Frame 3—SmartWire-DT and Standard (Non SmartWire-DT)

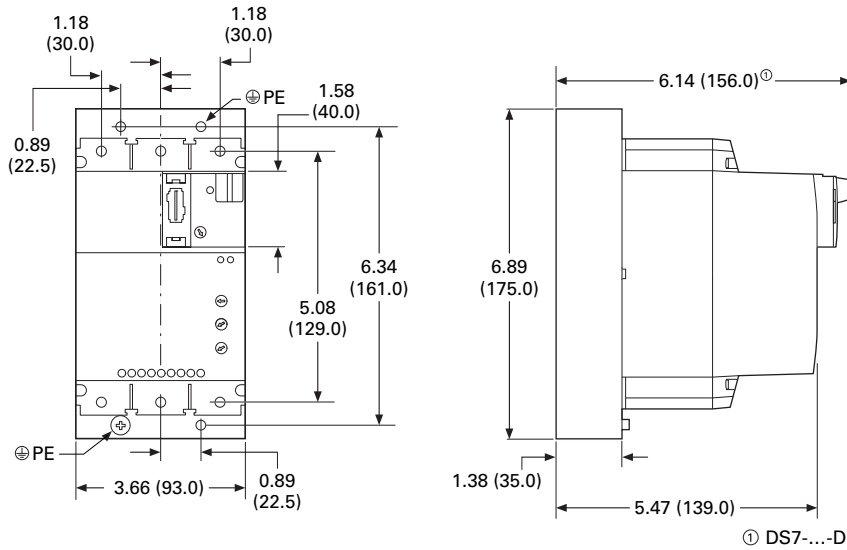

#### Catalog Numbers

DS7-340SX041N0-N	DS7-342SX041N0-N	DS7-34DSX041N0-D
DS7-340SX055N0-N	DS7-342SX055N0-N	DS7-34DSX055N0-D
DS7-340SX070N0-N	DS7-342SX070N0-N	DS7-34DSX070N0-D
DS7-340SX081N0-N	DS7-342SX081N0-N	DS7-34DSX081N0-D
DS7-340SX100N0-N	DS7-342SX100N0-N	DS7-34DSX100N0-D

### Frame 4—SmartWire-DT and Standard (Non SmartWire-DT)

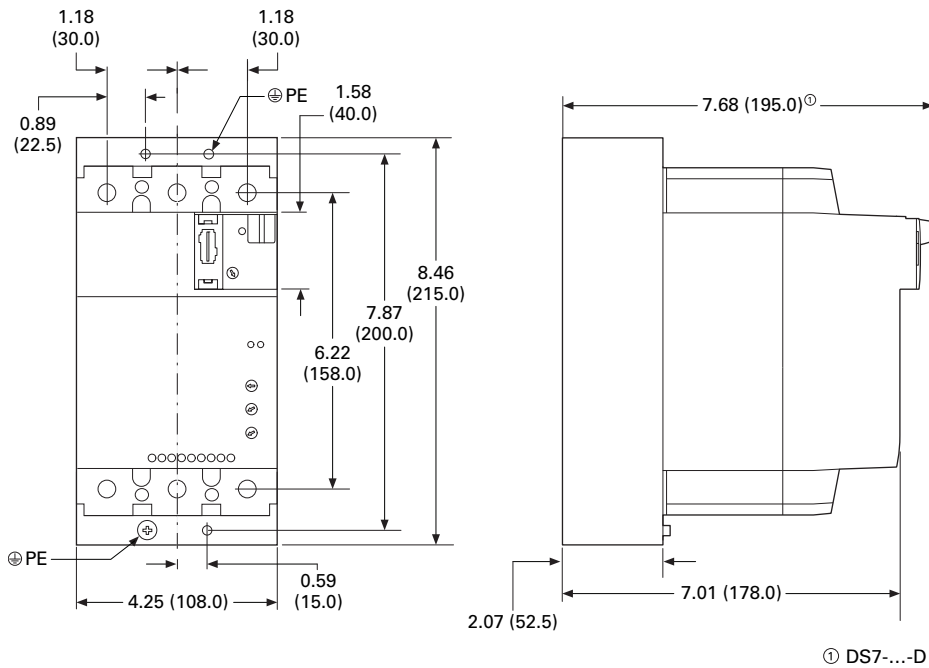

#### Catalog Numbers

DS7-342SX135N0-N	DS7-340SX135N0-N	DS7-34DSX135N0-D
DS7-342SX160N0-N	DS7-340SX160N0-N	DS7-34DSX160N0-D
DS7-342SX200N0-N	DS7-340SX200N0-N	DS7-34DSX200N0-D