

Freedom



Freedom Arc-Resistant MCC



Freedom FlashGard



3.1 MCC Product Offering

Product Overview	V3-T3-2
Aftermarket Products	V3-T3-3
Product Description	V3-T3-4
Application Description	V3-T3-4
Features, Benefits and Functions	V3-T3-4
Standards and Certifications	V3-T3-4
Accessories and Options	V3-T3-7

3.2 Freedom, Freedom Arc-Resistant and Freedom FlashGard®

Product Description	V3-T3-8
Features and Benefits	V3-T3-9
Standards and Certifications	V3-T3-10
Technical Data and Specifications	V3-T3-10

3.3 Freedom and Freedom FlashGard Check Sheets

Check Sheets	V3-T3-20
------------------------	----------

3.4 Freedom Arc-Resistant MCC Check Sheets

Check Sheets	V3-T3-24
------------------------	----------



Learn
Online

Freedom, Freedom Arc-Resistant and Freedom FlashGard



Contents

<i>Description</i>	<i>Page</i>
Aftermarket Products	V3-T3-3
Product Description	V3-T3-4
Application Description	V3-T3-4
Features, Benefits and Functions	V3-T3-4
Standards and Certifications	V3-T3-4
Accessories and Options	V3-T3-7

Product Overview

MCC Operation

Eaton’s motor control center (MCC) product line is headquartered in Fayetteville, NC. At Fayetteville, the most progressive engineering team in the industry can custom design motor control centers for the most demanding applications. Most MCCs can be shipped six to eight weeks after receipt of a released order.

The MCC product line also offers a FAST motor control center (MCC) quick shipment program. The program includes integration of a number of commonly used components and assemblies in MCC applications as well as configuration options for each. The FAST program also includes expedited delivery of customer approval drawings when predefined pilot/control device configurations for unit assemblies are selected. MCCs meeting the FAST criteria are shipped within 4 weeks after receipt of a released order.

Customer Manufacturing Solution Centers

One of the most unique aspects of the Eaton MCC operation is the ability to provide customized product to meet delivery requirements through a Customer Manufacturing Solution Center (CMSC). There are nine of these facilities located throughout the U.S. serving key geographic markets. Each CMSC has the ability to provide standard NEMA® 1B wired product in as little as one to three days. Please contact the facility in your area to discuss customer opportunities and MCC support for your specific marketplace.

Customer Manufacturing Solution Centers

Location	Telephone
Atlanta	678-309-4270
Chicago	630-260-6304
Denver	303-366-9949
Hartford	860-683-4221
Houston	713-939-9696
Los Angeles	562-944-6413
Portland	503-582-2700

Seismic Qualification

The Freedom and **XT** MCC families have been qualified to meet the seismic requirements of both the Uniform Building Code® (UBC) and the California Building Code (CBC) for equipment operation after seismic activity. This equipment, along with Eaton’s low and medium voltage switchgear assemblies, medium voltage starter assemblies and low voltage switchboards, which meet seismic requirements, provide the user with a complete seismic qualified assemblies package that meet CBC and IBC requirements. Please contact your Eaton sales engineer for more details.

Bid Manager™

One of the most exciting new tools developed for the MCC product line is the Bid Manager program. Bid Manager is a PC-based pricing program that is capable of providing complete bills of material, front views and prices for MCCs. This program can configure an MCC to meet a multitude of specific applications and provide accurate bills of material and front view drawings in a matter of moments. The program operates on a user-friendly, Windows®-based format that offers the most extensive product selection found in the industry. A complete line of adjustable frequency drives and reduced voltage solid-state control, along with insulated case breakers, high ampacity molded case breakers and automatic transfer switches are featured in the program. Control and distribution product can be packaged in a multitude of variations. Please contact your Eaton sales engineer for more details.

Aftermarket Products



Motor Control Center Production Years

2012–Present	1995–present	2002–2011	1992–2010	1987–1995/ 1975–1987	1988–1994	1972–1989	1965–1975	1956–1974	1935–1965
--------------	--------------	-----------	-----------	-------------------------	-----------	-----------	-----------	-----------	-----------

Background

Over 50 years ago, Cutler-Hammer® and Westinghouse® low voltage motor control centers were introduced, enabling the group mounting of low voltage (600 V class) electrical controls. This allowed for supervision and safe operation of motor starter units, feeder tap units and auxiliary equipment in a flexible structure arrangement at a centralized location.

The foundation for today’s MCCs is a modular plug-in combination motor controller assembly with components of proven electrical and mechanical integrity. These assemblies are enclosed in metal structures that prevent accidental contact with live electrical parts.

The MCC structure consists of structural steel, horizontal and vertical wireways for conduit and load cable entry and exit, and vertical and horizontal bus systems for distributing power throughout the MCC. The starter unit consists of a rugged steel shell (wrapper) for mounting the unit components, a combination motor starter with factory wired control, a handle mechanism for ON/OFF operation, and a rigid unit door.

Aftermarket Service

Eaton’s MCCs are manufactured with high quality structural parts designed to provide many years of service.

Eaton is dedicated to providing replacement units or add-on units to handle additional loads for motor control centers manufactured since 1935 for both the Westinghouse and Cutler-Hammer product lines.

The following descriptions and needed order entry information will be useful in identifying and processing a vintage MCC aftermarket unit.

1. Motor control center type: (11-300, Type W, 5-Star, Advantage, 9800, F-10, Freedom FlashGard, Freedom, Freedom arc-resistant **IT**, **XT** and **XT** FlashGard)
2. Class of unit (Non-reversing, Reversing, Two Speed)
3. Service voltage
4. Control voltage
5. Starter size or horsepower rating
6. Disconnect type (HMCP, Fusible)
7. Clip size and type (if Fusible)
8. Unit modifications (Lights, Pushbuttons, etc.)
9. Catalog Number (if available)

Product Availability

Replacement units for the 5-Star, Series 2100, Advantage, 11-300, 9800, Type W, F-10, F2100, Freedom FlashGard, Freedom, Freedom arc-resistant **IT**, **IT** FlashGard, **XT** and **XT** FlashGard motor control center lines may be obtained from the Fayetteville manufacturing plant or any of the regionally located Customer Manufacturing and Solution Centers (CMSCs).

Competitive MCC units can be obtained from the Fayetteville manufacturing plant or CMSCs.

They are located in:

Customer Manufacturing Solution Centers

Location	Telephone
Atlanta	678-309-4270
Chicago	630-260-6304
Denver	303-366-9949
Hartford	860-683-4221
Houston	713-939-9696
Los Angeles	562-944-6413
Portland	503-582-2700

MCC Renewal Parts

MCC Type	Dates	Eaton’s Cutler-Hammer Renewal Parts Publication
XT	2012–present	—
XT FlashGard	2012–present	—
IT	2002–2011	—
IT FlashGard	2007–2011	—
Freedom	1995–present	RP04304001E
Freedom FlashGard	2008–present	—
Advantage	1992–2011	RP04304002E
Series 2100	1987–1995	RP04304003E
5 Star	1975–1987	RP04304003E
Freedom Unitrol	1988–1994	RP04304004E
F10 Unitrol	1972–1989	RP04304005E
Type W	1965–1975	RP04304006E
9800 Unitrol	1956–1974	RP04304007E
11-300	1935–1965	RP04304008E

Product Description

Eaton’s offering of motor control centers (MCCs) features the Freedom, Freedom arc-resistant, Freedom FlashGard, **XT** and **XT** FlashGard. These MCCs incorporate the newest NEMA electromechanical starters in the industry along with the most complete, NEMA rated package of distribution and control equipment. The FlashGard MCCs are the industry’s first MCCs designed for comprehensive arc flash prevention.

Application Description

Eaton’s MCCs are custom-made assemblies of conveniently grouped control equipment primarily used for control of motors and for distribution of power. MCCs are designed for three-phase, 230 V applications up to 300 hp, or three-phase, 480 V applications up to 600 hp. The Freedom FlashGard and **XT** FlashGard MCCs are equipped with a state-of-the-art stab racking mechanism (RotoTract™) that provides bus isolation, stab indication and lockout features that proactively prevent the initiation of arc flash.

Features, Benefits and Functions

Structure Design

Eaton’s MCCs are 20.00 inches (508.0 mm) wide and 90.00 inches (2286.0 mm) high with vertical compartments having 72.00 inches (1828.8 mm) of unit mounting space in 6.00-inch (152.4 mm) increments.

Structure depth is 16.00 inches (406.4 mm) or 21.00 inches (533.4 mm) deep front-mounted only and 21.00 inches (533.4 mm) deep for back-to-back mounted units.

The unique framed design permits the highest flexibility in component and structure configuration.

Accessibility

All parts and wiring are front accessible. Terminal blocks are side mounted in each unit. 4.00-inch (101.6 mm) or 8.00-inch (203.2 mm) vertical wireways separate from control units provide safe and convenient access to wiring and conduits without de-energizing any equipment.

Flexibility

Modular, framed design permits structure arrangement to be tailored to exactly meet any control requirements with a minimum of unusable space. Vertical compartments are incremented for maximum space utilization and unit interchangeability. Compact starter and feeder units provide users with the ability to solve demanding space requirements and still meet all NEMA and UL® standards.

Safety

Design tested at Eaton’s power laboratory to ensure maximum protection for control equipment. The FlashGard option ensures maximum safety for personnel working on or around the equipment.

Hardwired Control

With choices for 1A to 2C wiring schemes, the Eaton MCC offers many options for traditional or supervisory control schemes.

Industrial Communications

Eaton MCCs come with the most advanced and flexible industrial factory installed and tested communication connectivity in the marketplace with protocols that include DeviceNet, Modbus and Modbus TCP, EtherNet/IP and PROFIBUS. Eaton smart MCCs facilitate faster startup, safer working conditions and enhanced diagnostics and monitoring.

Intelligent Products

Eaton MCCs include intelligent starters, soft starters, VFDs, meters and feeder breakers that can all be connected to an embedded PLC and operator interface.

Standards and Certifications

UL Listing

Standard structures and units are provided with UL label.

Contact Eaton for details and part numbers for CSA approved units.



Comparison of Key MCC Features and Attributes by MCC Type/Family

MCC Type/Family	Serves Applications 480 V and Below	Serves 600 V Applications	Compact Unit Offering Standard ①	Compact Unit Offering Optional ①	120 Vac Control Power	24 Vdc Control Power	Tested and Certified Per Arc-Resistant Guidelines	FlashGard Technology ②	FlashGard Technology with Test Position ②③	Optional Communications Capability
Freedom	■	■		■	■					■
Freedom Arc-Resistant	■	■		■	■		■			■
Freedom FlashGard	■	■			■			■		■

Notes

- ① Compact offering has size 1 and 2 FVNR starter units in 1X and size 3 and 4 in 2X. Add 1X to each for FVR versions.
- ② FlashGard technology enables stabs to be retracted from and engaged onto the vertical bus while the unit’s door is closed.
- ③ FlashGard test position enables control power to be delivered to the unit while its stabs are removed from the vertical bus (no line power present within unit).

Catalog Number Selection

Aftermarket MCC Starter Buckets

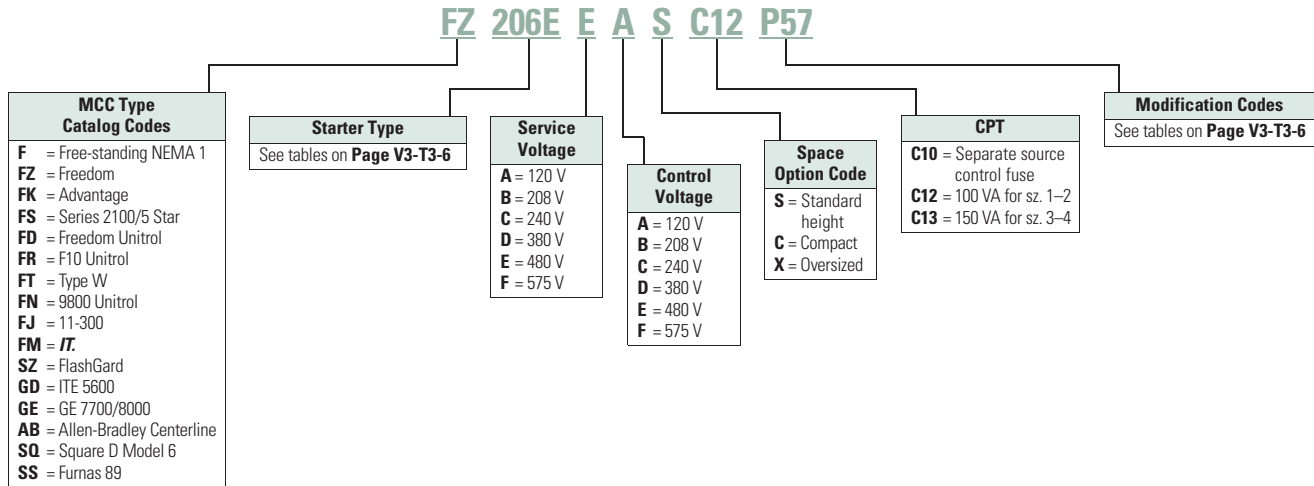

Aftermarket MCC Feeder Buckets/Units

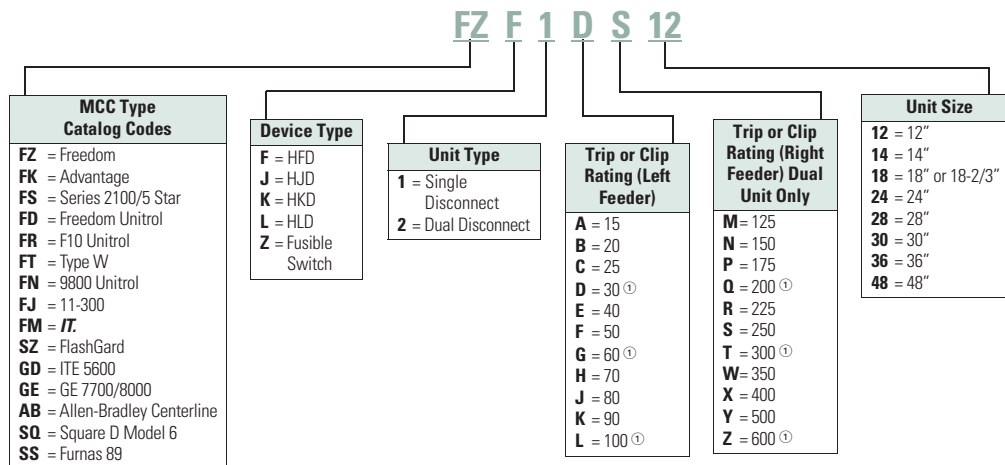

Aftermarket Service

Eaton’s MCCs are manufactured with high quality structural parts designed to provide many years of service.

Eaton is dedicated to providing replacement units or add-on units to handle additional loads for motor control centers manufactured since 1935 for both the Westinghouse and Cutler-Hammer product lines.

The following descriptions and needed order entry information will be useful in identifying and processing a vintage MCC aftermarket unit.

1. Motor control center type (refer to MCC types listed above for both starter and feeder units)
2. Class of unit (non-reversing, reversing, two speed)

3. Service voltage
4. Control voltage
5. Starter size or horsepower rating
6. Disconnect type (HMCP, Fusible)
7. Clip size and type (if fusible)
8. Unit modifications (lights, pushbuttons, etc.)
9. Catalog number (if available)

Note

① Fusible disconnect sizes.

Aftermarket MCC Starter types**Full-Voltage Non-Reversing Combination Starter—HMCP Disconnect**

NEMA Size	Maximum Horsepower					HMCP Ampere Size	Starter Class Code
	208 V	240 V	380 V	480 V	600 V		
1	0.50	0.33	1	1	1.50	3	206A
1	1	1	2	3	3	7	206B
1	3	3	5	7.50	7.50	15	206C
1	7.50	7.50	10	10	15	30	206D
2	10	15	25	25	30	50	206E
3	25	30	50	50	50	100	206H
4	40	50	75	100	100	150	206L

Full-Voltage Reversing Combination Starter—HMCP Disconnect

NEMA Size	Maximum Horsepower					HMCP Ampere Size	Starter Class Code
	208 V	240 V	380 V	480 V	600 V		
1	0.50	0.33	1	1	1.50	3	216A
1	1	1	2	3	3	7	216B
1	3	3	5	7.50	7.50	15	216C
1	7.50	7.50	10	10	15	30	216D
2	10	15	25	25	30	50	216E
3	25	30	50	50	50	100	216H
4	40	50	75	100	100	150	216L

Full-Voltage Non-Reversing Combination Starter—Fusible Disconnect

NEMA Size	Maximum Horsepower					Fuse Ampere Size	Starter Class Code
	208 V	240 V	380 V	480 V	600 V		
1	7.50	7.50	10	10	15	30	204D
2	10	15	25	25	30	50	204E
3	25	30	50	50	50	100	204H
4	40	50	75	100	100	150	204L

Full-Voltage Reversing Combination Starter—Fusible Disconnect

NEMA Size	Maximum Horsepower					Fuse Ampere Size	Starter Class Code
	208 V	240 V	380 V	480 V	600 V		
1	7.50	7.50	10	10	15	30	214D
2	10	15	25	25	30	50	214E
3	25	30	50	50	50	100	214H
4	40	50	75	100	100	150	214L

Common Modifications

Abbreviated list of common modification codes

Note: Please contact your local Service Center for all available modifications and to learn which modifications will work for your aftermarket needs.

Modification Codes	Option Description
B10	Breaker shunt trip—120 V
B11	Breaker auxiliary switch—1NO/1NC
B19	Breaker auxiliary switch—2NO/2NC
C10	Control fuse wired for separate source in lieu of CPT
C11	Control fuse/disconnect for separate source in lieu of CPT
C12	CPT 100 VA for size 1 and 2 starters, fused
C13	CPT 150 VA for size 3 and 4 starters, fused
C18	Full capacity CPT for size 5 starters, fused
M12	Mini elapsed time meter
M16	IQ 200 Meter with three CTs
O19	Overload relay heater/heater pack
O20	Standard solid-state overload relay
P10	Red 'RUN' light
P11	Green 'STOPPED' light
P15	Red 'RUN' Push-to-Test light
P16	Green 'STOPPED' Push-to-Test light
P20	Special function light
P32	'START/STOP' pushbutton
P35	'ON/OFF' pushbutton
P36	'FORWARD/REVERSE/STOP' pushbutton
P38	'FAST/OFF/SLOW' pushbutton
P41	Special function pushbutton
P50	'ON-OFF' selector switch
P53	'START-STOP' selector switch
P55	'FORWARD-REVERSE' selector switch
P56	Special function 2-position selector switch
P57	'HAND-OFF-AUTO' selector switch
P58	'LOCAL-OFF-REMOTE' selector switch
P59	'FAST-OFF-SLOW' selector switch
P60	'HIGH-OFF-LOW' selector switch
P61	Special function 3-position selector switch
R24	D15 four-pole control relay
S11	1NO-1NC starter auxiliary contacts
S22	2NO-2NC starter auxiliary contacts
T10	Pull-apart type terminal blocks (standard on all vintages except Type W and 11-300)
U10	Surge suppressor on coil
U11	Type SIS control wire
U14	Wiremarkers—sleeve type on all control wire
U17	Wiring diagram inside starter unit door

Accessories and Options

Control and Distribution Equipment Packaging

Eaton's MCCs provide the best packaged solutions for the control needs of today's users. Structural characteristics allow the user to select a complete package of control and distribution equipment in a minimum amount of space. The ability to package a wide range of solid-state products, including SVX9000 drives, S811+ soft starters and PLCs meet the most demanding user process needs. The option to provide high ampacity molded case breakers gives the user the flexibility to minimize switchboard or switchgear structures and thereby saves valuable space and reduces design costs. Additional safety accessories are available such as Motorguard (automatic insulation tester), Voltage Vision (voltage presence indicator), FlashGard remote racking accessory and FlashGard locking accessory. Other packaged products, including automatic transfer switches and panelboards, again reduce space requirements and save time and money on equipment and installation costs. A motor load terminal block that enables quick connect/disconnect of 480 V power is available as standard on the Freedom FlashGard as well as the **XT** and **XT** FlashGard MCCs. This feature is optional on the Freedom and Freedom arc-resistant MCCs.

FlashGard Remote Racking Accessory



Remote Racking Accessory

- Performs RotoTract racking safely behind NFPA arc flash boundaries
- 120 Vac motor driven
- Mounts to RotoTract mechanism
- Wired pendant station for "rack-in"/"rack-out" operation
- Momentary jog
- Mounting offset bracket to clear device panel

Voltage Presence Indicator (VoltageVision™)

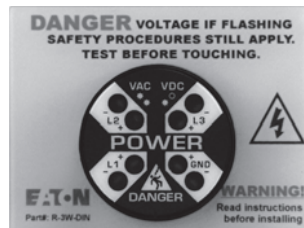

Voltage Presence Indicator (VoltageVision)

- Hardwired voltage detector connected to load side of disconnect
- Enables operator to "pre-verify" voltage presence with unit door closed
- Installable in a 30 mm pilot device knockout
- Dual redundant circuitry for reliability
- Phase insensitive

FlashGard Locking Accessory



FlashGard Locking Accessory

- Locks out RotoTract operation during maintenance
- Allows operation of FlashGard units by authorized personnel only
- Heavy-gauge steel construction

Automatic Insulation Tester (Motorguard)

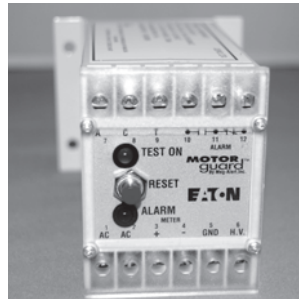

Automatic Insulation Tester (Motorguard)

- "Meggers" equipment motor insulation to continuously monitor integrity of insulation for the period that the equipment is de-energized
- Applies 500 Vdc potential at current-limited, operator-safe maximum amperage of 200 microamperes
- Alarms upon detection of a threshold leakage to ground current
- Visual alarm indication and lockout; Form C contact available for remote alarm status

Freedom Arc-Resistant Motor Control Center



Contents

<i>Description</i>	<i>Page</i>
Features and Benefits	V3-T3-9
Standards and Certifications	V3-T3-10
Application Guide	V3-T3-18
Product Specifications	V3-T3-19

Freedom Arc-Resistant Motor Control Center

Product Description

An arc flash is a dangerous condition associated with the explosive release of energy caused by an electrical arc due to either a phase-to-ground or a phase-to-phase fault. This fault can result from many factors, including dropped tools, accidental contact with electrical systems, buildup of conductive dust, corrosion and improper work procedure. An arc-flash event releases a tremendous amount of energy in the form of thermal heat, toxic fumes, pressure waves, blinding light, sound waves and explosions that can result in serious injury, including critical burns, collapsed lungs, loss of vision, ruptured eardrums, puncture wounds and even death.

Temperatures can reach 35,000 °F, which is three times hotter than the temperature of the sun. These excessive temperatures cause the air and metal in the path of the arc to expand and explode, creating an arc blast. Throughout the world, arc flash threatens personnel safety, and companies face lost man-hours, lawsuits, fines, equipment damage, facility downtime and lost production.

In continuation with the legacy of Eaton’s leadership in arc flash safety products, the Freedom arc-resistant motor control center (MCC) is designed to provide personnel with increased protection from the dangers of arc flash hazards. This enhanced version of Eaton’s flagship Freedom MCC includes additional features specifically designed to contain the arc blast energy should an arc flash event be triggered within the assembly. The Freedom arc-resistant MCC has a Type 2 accessibility rating, meaning that arc-resistant designs or features are present on the front, back and sides of the assembly. This Type 2 rating translates to enhanced safety around the entire perimeter of the MCC should an arc flash event occur.

Features and Benefits

No Exhaust Plenums or Roof Flaps Required

Eaton’s arc-resistant Freedom MCC requires no exhaust plenums or roof flaps. This aids in the ease of installation, as additional clearance or venting ductwork is not required above the assembly.

12 Gauge Steel Doors, Side Sheets and Back Sheets

Usage of 12 gauge steel on all MCC doors, side sheets and back sheets serve to increase the structural integrity of the MCC and aid in the containment of arc blast energy, further enhancing personnel safety should an arc flash event occur.

4 Inch Sections

A four-inch section is added to the first and last structures of the MCC lineup, regardless of the number of structures. These sections increase the structural integrity of the MCC lineup, further ensuring it can withstand the arc blast energy.

Enhanced Door Hinges and Latches

Hinges and door latches play a vital role in the containment of arc blast energy during an arc flash event. The design and implementation of enhanced door hinges and latches on the Freedom arc-resistant MCC serves to keep doors closed and latched securely during an arc flash event, further preventing the propagation of arc blast energy toward personnel. As an additional measure, the quantity of door hinges and latches applied to the MCC unit doors has also been increased.

Insulated Horizontal and Vertical Buses

Insulation of the horizontal and vertical buses aids in the prevention of arc flash incidents. When an arc flash incident does occur, the insulation serves to prevent further propagation of the arc fault throughout the entire MCC. Automatic vertical bus shutters are included.

Isolation Barriers Between Adjacent Structures

Isolation barriers placed between adjacent structures serve to isolate the arc blast energy to a single area within the MCC.

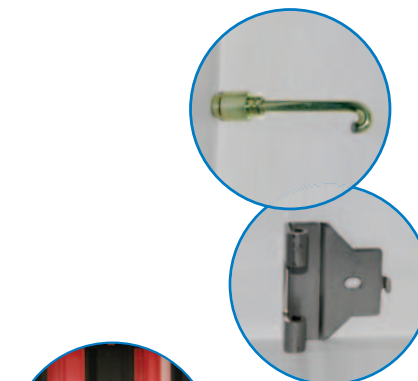

Standards and Certifications

Eaton's Freedom arc-resistant MCC has been tested and verified per the criteria found in the Institute of Electrical and Electronics Engineers (IEEE) guideline C37.20.7 titled "IEEE Guide for Testing Metal-Enclosed Switchgear Rated Up to 38 kV for Internal Arcing Faults."

The MCC also meets the criteria found in Canadian Standards Association (CSA) standard C22.2 No. 0.22-11, titled "Evaluation Methods for Arc Resistance Ratings of Enclosed Electrical Equipment." This standard was originally published in 2012 and is currently the only official North American standard or guideline that contains low voltage MCCs within the scope of coverage. CSA C22.2 No. 0.22-11 was based in large part on the guidelines and testing criteria found in IEEE C37.20.7.

Technical Data and Specifications

Specifications

Item	Description
Freedom Arc-Resistant MCC	
Applicable guidelines and standards	Tested and verified per IEEE guideline C37.20.7 and CSA standard 22.2 No. 0.22-11
Agency approvals	UL and cUL per UL 845
Voltage rating	600 V maximum
Interrupting rating	Maximum 65 kA at 480 V and 600 V
Arc duration rating	100 ms at 480 V, 50 ms at 600 V
Accessibility type ^①	Type 2 (contains arc-resistant protection designs or features on the front, sides, and rear of the equipment)
Main incoming breaker (required)	2500 A frame 1200 A–2500 A trip range), 80% rated 1200 A frame (400 A–1200 A trip range), 80% rated
Structure environmental ratings	NEMA 1, 2
Structure depth	21 inches
Horizontal bus	Minimum 800 A, maximum 2500 A ^②
Vertical bus	Maximum 1200 A
Bus insulation	Horizontal and vertical buses both insulated
Available Units, Assemblies and Options	
Interrupting devices ^③	Thermal-magnetic circuit breakers and motor circuit protectors
Main breakers ^④	2500 A frame (800 A–2500 A range) 1200 A frame (320 A–1200 A range)
Starters	NEMA size 1–5 full voltage non-reversing (FVNR), full voltage reversing (FVR) and multi-speed All overload options available, including bimetallic and solid-state
Feeders	Maximum 600 A, 80% rated
Variable frequency drives (VFDs)	Maximum 150 hp ^⑤
Soft starters	Maximum 200 hp
Other units and assemblies available	Relay panels Relay structures Meters Transformers Panelboards Surge protective devices Power factor correction capacitors Active harmonic correction units
Communications	Communications on all major fieldbus protocols, including Modbus, Modbus TCP, EtherNet/IP, DeviceNet, and PROFIBUS

Notes

- ① Freedom arc-resistant MCCs containing clean power drives carry a Type 1 accessibility type (contains arc-resistant protection designs on the front).
- ② 2500 A maximum with 65 °C temperature rise bus, 2000 A maximum with 50 °C temperature rise bus.
- ③ Fused switches and air circuit breakers not available.
- ④ An incoming main breaker is required to be configured in the lineup. Incoming main lugs, fused switches and air circuit breakers not available as main devices.
- ⑤ FR8 min size enclosure only up to 150 hp.

Freedom, Freedom Arc-Resistant and Freedom FlashGard Technical Data and Specifications

Incoming Line

Incoming Line—
Main Lugs Only ^{1 2}

Bus Rating	X-Space
600	2
	3
	4
800	3
	4
	6
1000	4
	6
	8
1200	5
	6
1600	12
2000	12
2500	12
3200 ³	12

Incoming Line—Main Circuit Breaker ^{1 4}

Frame Size (Amperes)	Circuit Breaker Type	Dimensions in Inches (mm)	
		Freedom, Freedom Arc-Resistant and Freedom FlashGard Unit Size	Enclosure Width
150	HFD ²	18.00 (457.2)	20.00 (508.0)
	FDC ²	18.00 (457.2)	20.00 (508.0)
225	HFD ²	18.00 (457.2)	20.00 (508.0)
	FDC ²	18.00 (457.2)	20.00 (508.0)
250	HJD ²	30.00 (762.0)	20.00 (508.0)
	JDC ²	30.00 (762.0)	20.00 (508.0)
400	HKD ²	30.00 (762.0)	20.00 (508.0)
	KDC ²	30.00 (762.0)	20.00 (508.0)
	CHKD ^{2 5}	30.00 (762.0)	20.00 (508.0)
	CKDC ^{2 5}	30.00 (762.0)	20.00 (508.0)
600	HLD ²	24.00 (609.6) ^{6 9 10 11}	20.00 (508.0)
	LDC ²	24.00 (609.6) ^{6 9 10 11}	20.00 (508.0)
	CHLD ^{2 3 5}	24.00 (609.6) ^{6 9 10 11}	20.00 (508.0)
	CLDC ^{2 3 5}	24.00 (609.6) ^{6 9 10 11}	20.00 (508.0)
800	HMDL ²	30.00 (762.0) ^{6 11}	20.00 (508.0)
	CHMDL ^{2 3 5}	48.00 (1219.2) ^{9 11}	20.00 (508.0)
	NGH ^{4 6 7}	42.00 (1066.8) ^{9 11}	20.00 (508.0)
	NGC ^{2 6 7}	42.00 (1066.8) ^{9 11}	20.00 (508.0)
	NGH-C ^{3 6 7 8}	72.00 (1828.8) ⁹	20.00 (508.0)
	NGC-C ^{2 6 7}	72.00 (1828.8) ⁹	20.00 (508.0)
1200	NGH ^{4 6 7}	42.00 (1066.8) ^{9 11}	20.00 (508.0)
	NGC ^{2 6 7}	42.00 (1066.8) ^{9 11}	20.00 (508.0)
	NGH-C ^{2 3 4 6 7 8}	72.00 (1828.8) ⁹	20.00 (508.0)
	NGC-C ^{2 3 6 7}	72.00 (1828.8) ⁹	20.00 (508.0)
1600	RGH ^{4 6 7}	72.00 (1828.8) ^{9 12}	20.00 (508.0)
	RGC ^{2 6 7}	72.00 (1828.8) ^{9 12}	20.00 (508.0)
	RGH-C ^{2 4 6 7 8}	72.00 (1828.8) ^{9 12}	20.00 (508.0)
	RGC-C ^{2 6 7 8}	72.00 (1828.8) ^{9 12}	20.00 (508.0)
2000	RGH ^{4 6 7}	72.00 (1828.8) ^{9 12}	20.00 (508.0)
	RGC ^{2 6 7}	72.00 (1828.8) ^{9 12}	20.00 (508.0)
	RGH-C ^{2 4 6 7 8}	72.00 (1828.8) ^{9 12}	20.00 (508.0)
	RGC-C ^{2 6 7 8}	72.00 (1828.8) ^{9 12}	20.00 (508.0)
2500	RGH ^{4 6 7}	72.00 (1828.8) ^{9 11 12}	24.00 (609.6)
	RGC ^{2 6 7}	72.00 (1828.8) ^{9 11 12}	24.00 (609.6)

Notes

- ¹ Table common to Freedom, Freedom arc-resistant and Freedom FlashGard.
- ² Not available in Freedom arc-resistant MCC.
- ³ NEMA 1 gasketed only.
- ⁴ An NGH or RGH main breaker is required in the Freedom arc-resistant MCC. The NGH requires a complete vertical section (72 inches) in the Freedom arc-resistant MCC only.
- ⁵ 100% rated when 90° cable applied at 75° ampacity for 100% rating. Digitrip™ 310 LS is required and included in the price.
- ⁶ Digitrip 310+ LSI is standard and included in the pricing.
- ⁷ Arcflash Reduction Maintenance System (ARMS) available. Requires Digitrip 310+ ALSI or ALSIG.
- ⁸ 100% rated when 90° cable applied at 75° ampacity for 100% rating.
- ⁹ Fixed assembly. Not available with FlashGard RotoTract assembly.
- ¹⁰ Add 6.00 inches (152.4 mm) for top entry of incoming cables.
- ¹¹ Install at top for cable top entry or at bottom for bottom cable entry.
- ¹² The main breaker requires the complete vertical section. The rear is unusable.

Structure Modifications

Structure Modifications

Description
Enclosure
NEMA 1 gasketed
NEMA 12—dust-tight ①
NEMA 3R front-mounted only ①
NEMA 3R front and rear ①
NEMA 3R walk-in ①
NEMA 3R tunnel ①
Space heater
Thermostat
Bottom plate
Channel sills
12.00-inch (304.8 mm) pull box
100 kA bus bracing ①
Vertical Bus
600 A
800 A
1200 A
Horizontal Ground Bus
300 A copper
600 A copper
800 A copper
Standard Structures
16.00-inch (406.4 mm) front-mounted only ①
21.00-inch (533.4 mm) front-mounted only
21.00-inch (533.4 mm) front and rear ①
Main Horizontal Bus—65°C Rise ①
600 A copper ①
800 A copper
1200 A copper
1600 A copper
2000 A copper
2500 A copper
3200 A copper ①
Vertical Bus Barrier
Labyrinth barrier with shutters ②

Neutral Bus (Bottom)

Ampere Rating
300
600 or 800
1000
1200
1600
2000
2500
3200 ①③

Incoming Line Metering

Meter	X-Space Freedom, Freedom Arc-Resistant and Freedom FlashGard
IQ 130/140/150	2
IQ 250/260	2
IQ DP-4130	2
IQ Analyzer	2
Power Xpert 2250/2260/2270	2
Power Xpert 4000/6000/8000	3

Surge Protective Device—Units with Circuit Breaker Disconnect

Three feature packages are available to choose from. Individual features vary by package.

Surge Current Per Phase	X-Space Freedom, Freedom Arc-Resistant and Freedom FlashGard
100 kA Model SPD ④	3
120 kA Model SPD ④⑤	3
160 kA Model SPD ④	3
200 kA Model SPD ④	3
250 kA Model SPD ⑥	3
300 kA Model SPD	3
400 kA Model SPD	3

Notes

- ① Not available in Freedom arc-resistant MCC.
- ② Labyrinth barrier with automatic shutter is standard on the Freedom arc-resistant MCC.
- ③ Available NEMA 1 gasketed enclosures only.
- ④ Optional integral IQ 200 Meter in 3X unit for 100 kA–200 kA.
- ⑤ Recommended for branch entrance.
- ⑥ Recommended for service entrance.

Combination Starters

Circuit Breaker Starters (HMCP) Non-Reversing (F206) ①

Size	X-Space	
	Freedom and Freedom Arc-Resistant	Freedom FlashGard
1	2	2
2	2	2
3	3	3
4	3	4
5	6	7
6	9	9

Compact Circuit Breaker Starters (HMCP) Non-Reversing (F206)

Size	X-Space	
	Freedom and Freedom Arc-Resistant	
1	1	
2	1	
3	2	
4	2	

Compact Circuit Breaker Starters (HMCP) Reversing (F216)

Size	X-Space	
	Freedom and Freedom Arc-Resistant	
1	2	
2	2	
3	3	
4	3	

Circuit Breaker Starters ①

Size	X-Space	
	Freedom and Freedom Arc-Resistant	Freedom FlashGard

Full Voltage Reversing (F216)		
1	3	3
2	3	3
3	4	4
4	5	5

2S1W (F946)		
1	4	4
2	4	5
3	6	7
4	6	8

2S2W (F956)		
1	4	4
2	4	4
3	5	5
4	5	7

Reduce Voltage Auto Transformer (F606) ②		
3	8	9
4	8	9
5 ③	12	12
6 ④	12	12

Vacuum Starters (V206) Non-Reversing		
4	3	4
5	6	7
6	8	9

Fusible Disconnect Starters ①

Size	X-Space	
	Freedom and Freedom Arc-Resistant	Freedom FlashGard

Full Voltage Non-Reversing (F204)		
1	2	3
2	2	3
3	4	4
4	6	6
5	10	11

Full Voltage Reversing (F214)		
1	4	4
2	4	4
3	5	5
4	8	10

Fusible Non-Reversing 2S 1W (F944)		
1	4	4
2	4	5
3	6	6
4	10	10

Fusible Non-Reversing 2S 2W (F954)		
1	4	4
2	4	5
3	5	6
4	8	10

Contactor Only Units

Size	X-Space	
	Freedom and Freedom Arc-Resistant	Freedom FlashGard

Circuit Breaker (F208)		
1	2	2
2	2	2
3	3	3
4	3	4
5	6	7
6	9	9

Fusible (F209) ⑤		
1	2	3
2	2	3
3	4	4
4	6	6
5	10	11

Notes

- ① All starter configurations use the Freedom contactor as standard. It is possible to order the starter configuration with the A200 contactor, which may affect X space.
- ② Must be located at bottom.
- ③ 24.00 inches (609.6 mm) wide.
- ④ 28.00 inches (711.2 mm) wide.
- ⑤ Not available in Freedom arc-resistant MCC.

Starter Modifications

Control Options

Description

Selector switch 2/3—Pos.
Push-to-test light 6 V transformer
Tx indicating light—standard
Auxiliary switch—in breaker
Mini meters
AMM
VMM
ETM
Relay surge suppressor
Timer—pneumatic
Timer—solid-state
Relay—AR—600 V two-pole
Relay—general purpose 300 V
Standard solid-state overload relay ^{①②}
NEMA size 1–3
NEMA size 4–6

Industrial Communications ^③

Networked-enabled components in MCCs eliminate up to 90% of the control wiring versus traditional hardwired designs.

The industrial network is prewired throughout the MCC and factory tested for conformance.

Motor Control Communication Options

Device	DeviceNet	Modbus	PROFIBUS	EtherNet/IP	Modbus TCP
C306 Over Load	C441KS	C441N	C441SS	C441R	C441R
C440 Over Load	C441K	C441NS	C441SS	C441R	C441R
C441 Over Load	C441K	C441N	C441S	C441R	C441R
SVX Drives	OPTC7	OPTC2	OPTC3	OPTCIQ	OPTCI
Feeders	C441KS	C441N	C441SS	C441R	C441R
S811+ Soft Starter	C441KS	Resident in S811+	Via gateway	C441V	C441V

S811+ Soft Starters with Integral Bypass

Maximum hp	X-Space		Maximum hp	X-Space	
	Freedom and Freedom Arc-Resistant	Freedom FlashGard		Freedom	Freedom FlashGard
1.15 Service Factor—Standard Duty			1.15 Service Factor—Severe Duty		
20	2	3	10	2	3
40	2	3	25	2	3
60	3	4	40	3	4
75	3	4	50	3	4
125	6	7	75	6	7
150	6	7	100	6	7
200	6	7	125	6	9
300 ^④	9	9	150	9	10
350 ^④	9	9	200	9	10
450 ^④	12	12	250 ^④	9	10
500 ^④	12	12	300 ^④	9	10
600 ^④	12	12	350 ^④	9	10
700 ^④	12 ^⑤	12	450 ^④	12 ^⑤	12

S811+ Control Options ^⑥

Description

Pump control
MOV protection

S811+ Power Options ^⑥

NEMA Bypass Contactor

Size 1
Size 2
Size 3
Size 4
Size 5
Size 6
Size 7

Notes

- ① Feature Overload provides same features as standard model plus ground fault, stall/jam protection, selectable trip class —10, 15 and 20.
- ② Size 4 units require additional 6-inch (152.4 mm) (1X) space.
- ③ This table is common for Freedom, Freedom arc-resistant and Freedom FlashGard MCCs.
- ④ Not available in Freedom arc-resistant MCC.
- ⑤ Requires 24.00-inch (609.6 mm) wide, rear is unusable, bottom exit only.
- ⑥ Options apply to both HMCP and breaker models.

Motor Isolation Contactors

Sizes
1
2
3
4
5
6
7

MMX Adjustable Frequency Drives—NEMA 1 (480 V Maximum)

hp	X-Space Freedom, Freedom Arc-Resistant and Freedom FlashGard	
	1	2
2	2	
3	3	
5	3	
7.5	3	
10	3	

MMX Drive Options

Description
3% load reactor
5% load reactor
Three contactor bypass

SVX9000 Adjustable Frequency Drives—Plug-in Units NEMA 1 (480 V Maximum) Constant/Variable Torque Rated ①

hp	X-Space Freedom and Freedom Arc-Resistant Freedom FlashGard	
	3	3
5	4	7
7.5	4	7
10	4	7
15	4	7
20	6	10
25	6	10
30	6	10

SVX9000 Options

Description
DeviceNet communications
PROFIBUS communications
Modbus RTU
Modbus TCP
EtherNet/IP
2000-foot (609.6m) dV/dT filter (3 hp)
2000-foot (609.6m) dV/dT filter (5–15 hp)
2000-foot (609.6m) dV/dT filter (20–30 hp)
Input line fuses (3–30 hp)
RFI filter (3–30 hp)

SVX9000 Adjustable Frequency Drives—Non-Plug-in Units NEMA 1 (480 V Maximum) Constant/Variable Torque Rated

hp	X-Space Freedom and Freedom Arc-Resistant Freedom FlashGard	
	40	9
50	9	9
60	9	9
75 ②	9	9
100	12	12
125	12	12
150	12	12
200	12	12
250 ③	12	12
300 ③	12	12
400 ③	12	12
500 ③	12	12
600 ③	12	12
700 ③	12	12

Note: Consult *Eaton's Consulting Application Guide* for complete details on Drive/ Option Assembly Dimensions.

Note: SVX9000 Non-Plug-in Units with HMCP disconnect, 3% input line reactor, 3% output line reactor, door mounted Keypad, CPT.

Note: VT—Variable Torque drives are capable of producing 200% starting torque for 10 seconds and are rated for 10 seconds, and are rated 110% overload for 1 minute.

Note: CT—Variable Torque drives are capable of producing 200% starting torque for 10 seconds and are rated for 10 seconds, and are rated 150% overload for 1 minute.

SVX9000 Options

Description
DeviceNet communications
PROFIBUS communications
Modbus RTU
Modbus TCP
EtherNet/IP
2000-foot (609.6m) dV/dT filter (40–75 VT hp)
2000-foot (609.6m) dV/dT filter (100–150 VT hp)
2000-foot (609.6m) dV/dT filter (200–250 VT hp)
2000-foot (609.6m) dV/dT filter (300–400 VT hp) ③
2000-foot (609.6m) dV/dT filter (500–600 VT hp) ③
Input line fuses (40–150 VT hp) ③
Input line fuses (200–250 hp) ③
Input line fuses (300–400 hp) ③

Active Harmonic Correction for AC Drives

Description	X-Space Freedom and Freedom Arc-Resistant Freedom FlashGard	
	50 A harmonic correction	12 ④
100 A harmonic correction	12 ④	12 ④

18-Pulse Clean Power Drives—NEMA 1, (480 V Maximum) Variable Torque Rated ⑤

hp	X-Space Inches (mm) Wide ⑥
100	12, 40.00 (1016.0)
150	12, 40.00 (1016.0)
200	12, 60.00 (1524.0)
250 ⑦	12, 60.00 (1524.0)
300 ③⑦	12, 60.00 (1524.0) ⑦
400 ③	12, 60.00 (1524.0) ⑦
500 ③⑦	12, 106.00 (2692.4) ⑦

Notes

- ① SVX9000 plug-in units with HMCP disconnect, 3% input line reactor, 3% output line reactor, door-mounted keypad, CPT.
- ② X-space for 75 hp CT rated drive is 12X.
- ③ Not available in Freedom arc-resistant MCC.
- ④ Requires 24.00-inch (609.6 mm) wide structure.
- ⑤ Includes 5% input line reactor, 18-pulse rectifier, delta differential transformer.
- ⑥ X-space shown is common for both Freedom and Freedom FlashGard MCCs.
- ⑦ Extra space required for bypass contactor, consult factory.

3.2

Motor Control Centers

Freedom, Freedom Arc-Resistant and Freedom FlashGard Technical Data and Specifications

3

Feeders

Note: FlashGard RotoTract assembly available on circuit breakers 400 A and below.

Circuit Breaker

Amperes	X-Space	
	Freedom and Freedom Arc-Resistant	Freedom FlashGard
Standard Circuit Breakers		
HFD 50 ①	2	2
HFD 100 ①	2	2
HFD 150 ①	2	2
HJD 250	3	3
HKD 400	4	5
HLD 600	4	4 ②
NGH 1200	7 ③	7 ②
6.00-Inch (152.4 mm) Circuit Breakers		
EG125	1	N/A
JG250	1	N/A
Dual HFD Circuit Breakers		
50/50	2	④
50/100	2	④
100/100	2	④
100/150	2	④
150/150	2	④

Fusible Disconnect—Fusible Switch ⑤

Amperes	X-Space	
	Freedom	Freedom FlashGard
30 or 60	2	3
100	3	3
200	6	5
400	6	7
600	8	8

Fusible Disconnect—Dual Fusible Switch ④⑤

Amperes	Freedom X-Space
30	2
60	3
30	2

Notes

- ① HFDE breakers with RMS 310+ electronic trip unit available in 80 AF and 225 AF in 2X space.
- ② Fixed assembly, no RotoTract.
- ③ NGH breaker requires a full structure (12X) in the Freedom arc-resistant MCC.
- ④ Not available in Freedom FlashGard.
- ⑤ Not available in Freedom arc-resistant MCC.

NEMA 3R Drives ①

Constant/Variable Torque Rated (480 V Maximum)

Horsepower	X-Space, Width ②
1.5	5X, 24.00 (609.6)
2	5X, 24.00 (609.6)
3	5X, 24.00 (609.6)
5	5X, 24.00 (609.6)
7.5	12X, 24.00 (609.6)
10	12X, 24.00 (609.6)
15	12X, 24.00 (609.6)
20	12X, 24.00 (609.6)
25	12X, 24.00 (609.6)
30	12X, 24.00 (609.6)
40	12X, 24.00 (609.6)
50	12X, 32.00 (812.8)
60	12X, 32.00 (812.8)
75	12X, 32.00 (812.8)
100	12X, 32.00 (812.8)
125	12X, 32.00 (812.8)
150	12X, 32.00 (812.8)
200	12X, 32.00 (812.8) ③

Transformers

Transformers ②④

kVA	Primary Breaker Only X-Space	Primary and Secondary Breakers X-Space
Single-Phase		
3	4	4
5	4	4
7.5	4	4
10	4	4
15 ⑦	6	6
20 ⑦	6	6
25 ⑦	6	6
30 ⑦	6	6
45 ⑦	7	8
Three-Phase		
9 ⑦	6	6
15 ⑦	6	6
25 ⑦	6	6
30 ⑦	6	6
45 ⑦	6	6

Panelboards

Panelboards (240 V Maximum) ②⑤

Circuits	X-Space
18	4
30	5
42	6

Panelboards (480 V Maximum) ②⑤

Circuits	X-Space
14	6
26	8
32	8
42	10

Automatic Transfer Switches ①

Open Transition Three-Pole Only

Ampere Rating	Unit Width Inches (mm)	X-Space ②
100 ⑥	20.00 (508.0)	6
150 ⑥	20.00 (508.0)	6
100	20.00 (508.0)	8
150	20.00 (508.0)	8
225	20.00 (508.0)	8
300	20.00 (508.0)	8
400	24.00 (609.6) ⑦	12
600	24.00 (609.6) ⑦	12
800	24.00 (609.6) ⑦	12
1000	24.00 (609.6) ⑦	12
1000	44.00 (1117.6) ⑥	12
1200	44.00 (1117.6) ⑥	12
1600	44.00 (1117.6) ⑥	12
2000	44.00 (1117.6) ⑥	12

Notes

- ① Not available in Freedom arc-resistant.
- ② X-space shown is common for Freedom, Freedom arc-resistant and Freedom FlashGard MCCs.
- ③ Extra space required for bypass section. Consult factory.
- ④ Must have primary breaker. Must be located at bottom of structure.
- ⑤ Space for MLO. Branch breakers included.
- ⑥ Manually operated switch:
NTVS = Electronically operated non-automatic.
MTVX = Single handle manual operation.
- ⑦ Requires 21.00-inch (533.4 mm) deep structure.
- ⑧ Requires 37.00-inch (939.8 mm) deep structure, flush at the rear. 4.00-inch (101.6 mm) filler required.
- ⑨ Requires 42.00-inch (1066.8 mm) deep structure. 4.00-inch (101.6 mm) filler required.

3.2

Motor Control Centers

Freedom, Freedom Arc-Resistant and Freedom FlashGard Technical Data and Specifications

Application Guide

Motor Circuit Protector Selection Guide ^①

NEMA	Maximum Horsepower						HMCP
	200 V	208 V	230 V	380 V	460 V	575 V	
1	—	—	—	3/4	3/4	1	3
	3/4	1	1	2	2	3	7
	2	2	2	3	5	7-1/2	15
	5	5	5	10	10	10	30
	7-1/2	7-1/2	7-1/2	—	—	—	50
2	—	—	—	—	—	15	30
	10	10	10	15	20	25	50
	—	—	15	25	25	—	70
3	—	—	—	—	—	30	50
	15	20	20	30	40	50	100
	25	25	30	50	50	—	150
4	40	40	40	60	100	100	150
	—	—	50	75	—	—	250
5	50	50	60	—	125	150	250
	75	75	75	150	200	200	400
	—	—	100	—	—	—	600
6	150	150	200	300	350	400	600
	—	—	—	—	400	—	1200

Circuit Breaker Application Chart ^②

Frame	Frame Rating (Amperes)	Interrupting Rating (kA Symmetrical Amperes)		
		208/240 V	480 V	600 V
Standard Rating Molded Case Circuit Breakers				
HFD	150	65	65	25
HJD	250	65	65	25
HKD	400	65	65	35
HLD	600	65	65	35
NGH	1200	65	65	35
RGH	2500	65	65	50
High Interrupting Rating Molded Case Circuit Breakers				
FDC	150	100	100	35
JDC	250	100	100	35
KDC	400	100	100	50
LDC	600	100	100	50
NGC	1200	100	100	50
RGC	2500	100	100	65
Current Limiting Molded Case Circuit Breakers				
HFD/CL	150	100	100	100
HFD/CL	225	100	100	100
NBTRIPAC	300–800	100	100	100
Magnum DS Air Circuit Breakers				
MDS-608	800	65	65	65
MDS-C08	800	100	100	100
MDS-616	1600	65	65	65
MDS-C16	1600	100	100	100
MDS-620	2000	65	65	65
MDS-C20	2000	100	100	100
MDS-632	3200	65	65	65
MDS-C32	3200	100	100	100

Notes

- ① Suitable for use with NEMA Design B and D (high efficiency) motors.
- ② Refer back to charts for main breakers and feeder breakers for available product families. Circuit breakers can be supplied with optional CPT and optional shunt trip.

Individual CPT Sizes

Starter Size	Standard Transformer (VA)	Maximum Size in Standard Unit (VA)
FVNR, FVR, 2S2W		
1, 2	100	150
1, 2–6	100	100
3, 4	150	250
5, 6	500	500
4	150	250
5	150	250
6	250	350
RVAT		
3, 4	150	250
5, 6	500	500
2S1W		
1, 2, 3, 4	200	250
5, 6	500	500
Vacuum		
4	150	250
5	150	250
6	250	350

Product Specifications

Structure

- NEMA 1, 2, 3R or 12 enclosure
- Copper horizontal bus 600–3200 A ^①
- Fully rated copper vertical bus 600–1200 A
- Isolated vertical bus barrier standard on Freedom MCCs
- Optional insulated horizontal bus and/or insulated labyrinth vertical bus on Freedom MCCs
- Optional isolating barriers between structures ^②
- Insulated horizontal bus and insulated labyrinth vertical bus is standard on Freedom arc-resistant and Freedom FlashGard MCCs
- Heavy-duty spring operated quarter-turn door latches
- 65 kA and 100 kA bus bracing ^③

Units

- Freedom Motor Starters:
 - NEMA size 1–7 ^④
 - Bimetallic overload relay
 - Single-phase protection
 - Class 10 and 20 protection
 - Widest heater range with fewest styles in the industry
 - Optional solid-state overload relays
- HMCP with combination starter ratings of 65 kAIC and 100 kAIC at 480 V ^⑤
- Plug-in units up to 400 A
- Handle mechanism with positive trip indication
- Side-mounted positive latch terminal block
- Motor load terminal block is standard on FlashGard MCC and optional on Freedom and Freedom arc-resistant
- Compact units available
- Soft Starters:
 - S811+ (20–800 hp) ^⑥
- Adjustable Frequency Drives:
 - MMX (1–10 hp)
 - SVX9000 (2–700 hp) ^⑦
- K-Switch visible blade fused disconnect: ^⑧
 - 30–800 A
 - 100 kAIC at 600 V

- 10250T 30.5 mm heavy-duty oiltight pushbuttons
- Surge protection:
 - SPD Series (100–400 kA)
- Energy monitoring:
 - IQ 100 (amperes, volts)
 - IQ 250 (adds, Hz, watts, PF)
 - IQ 260 (adds THD, Contact I/O)
 - IQ Analyzer (adds trending, waveform display)
 - Power Xpert (adds high-end metering, power quality analysis, open communications and Web server gateway)

Notes

- ① 800–2500 A copper horizontal bus available in Freedom arc-resistant MCC.
- ② Isolating barriers standard in Freedom arc-resistant MCC.
- ③ 65 kA bus bracing available in Freedom arc-resistant MCC. 100 kA not available.
- ④ NEMA size 1–5 motor starters available in Freedom arc-resistant MCC.
- ⑤ Starter combination ratings 65 kAIC maximum in Freedom arc-resistant MCC.
- ⑥ 20–200 hp S811+ soft starters available in Freedom arc-resistant MCC.
- ⑦ 2–200 hp SVX9000 drives available in Freedom arc-resistant MCC.
- ⑧ Fused disconnects not available in Freedom arc-resistant MCC

3.3

Motor Control Centers

Freedom and Freedom FlashGuard Check Sheets

3

Freedom and Freedom FlashGuard



Contents

Description

Freedom and Freedom FlashGuard Check Sheets

Motor Control Center Takeoff Check Sheet

Customer/Job Name	Neg No.
MCC Model	
Freedom	Freedom FlashGuard
Service 60 Hz	208 V/230 V/ 480 V /575 V
Service 50 Hz	380 V/415 V
DC	125 V/250 V
Three-wire/four-wire	
Structure Configuration	
16-inch front mount	21-inch front mount
21-inch front and rear mount	
42-inch front mount back-to-back	
32-inch front mount back-to-back	
NEMA 1A/2DP/12/3RNWI/3R aisle/3R tunnel	
Enclosure Modifications	
Space heaters (150 W) 120 V/240 V	
Channel sills	CBC/IBC seismic qualified
Thermostat	Split proof
Bottom plates	Split rear cover
Corner structure	Vertical section barrier
8-inch vertical wireway	Special paint color (adder)
	ABS Certification
Handle extensions ("two meter rule")	
Top hat (certain sections)	12-inch/18-inch/24-inch
Top hat (all sections)	12-inch/18-inch/24-inch

Bus Rating and Options	
Horizontal bus	600 /800/1200/1600
21-inch deep structure only	2000/2500/3200
Bus plating	Silver (AG)/ tin (SN)
Bus temp rise	50 °C/ 65 °C
Insulated horizontal bus	
Vertical bus	600/800/1200
Ground bus	300/600/800
Location	Top /bottom
Vertical ground bus	Lugs: incoming /each end
Neutral bus (4 W only)	Half/full/ lug pad
Bus bracing	42K/ 65K /100K
Vertical bus barrier	STD Glastic sheet
	Labyrinth with/without shutter

Incoming Line Metering	
IQ 130/140/150	
IQ 250/260	
IQ DP-4130	
IQ Analyzer	
Power Xpert 2250/2260/2270	
Power Xpert 4000/6000/8000	
Incoming Protection	
SPD Series surge protective device	
Incoming Line MLO/Breaker/Switch	
Cable—top/bottom/bus duct	
Main trip: LS/LSI/LSG/LSIG/other	
Crimp lugs	Screw type lugs
Main tie main (MTM)	Auto throw over
Kirk key	Service entrance (SUSE)

MCC Spec Review Checklist, continued

Breaker Options	
Aux. contacts (1NO 1NC) (2NO 2NC)	
LS/LSI/LSIG/LSG trip units	
Under voltage release	Shunt trip
Panelboards	
14/18/26/30/32/42 count	1-pole/2-pole/3-pole
Starter Disconnect Type	
HMCP/TM. bkr./fusible	
NEMA wiring class	
1A/1B/2B/1C/2C/1S/2S	
If any type "C" choose MTB location: Master terminal blocks (MTBs) top/bottom/relay structure	
Terminal Blocks	
Side latch pull apart (Std) (2x7-point)	
Spare points = _____% (call DSE)	Front utility (call DSE)
Nameplates: Black with White Letters / White with Black Letters	
Starter OL Types	
Bimetallic (C306)	Advanced solid-state (C441)
Solid-state (C440)	
Plug-In Starter Bucket Unit Features	
# 16 MTW wire	Coil surge suppression
# 14 SIS wire	Blown fuse indicators
# 14 MTW	Ground fault relays
Wiremarkers each end	
Ring wire lugs control	Riley current sensor
Spade wire lugs	Heater packs
Ring power wire lugs	
Wiring diagram on door	
SIS power wire	Vacuum contactors

Control Power	
Size 1 100 VA (Std)/150 VA max.	
Size 2 100 VA (Std)/150 VA max.	
Size 3 150 VA (Std)/250 VA max.	
Size 4 150 VA (Std)/250 VA max.	
Size 5 250 VA (Std)/300 VA max.	
Size 6 250 VA (Std)/300 VA max.	
Separate source power	
Auxiliary Starter Contacts	
NO 1/2/3/4	NC 1/2/3/4
Control Devices	
Pushbutton 1 unit/2 unit/reset	VoltageVision
Selector switch 2pos/3pos/4pos	Motorguard
Light—Std Xfmr/PTT/LED bulb	Motor load block
On/off run/stop	
Mini ETM	Panel ETM
AMM (mini/panel)	VM (mini/panel)
Riley transducer (Loop/Self Pwr)	
CTs for remote metering	
Ground fault	
IP relay—size 1/2/3/4/5/6	Voltage
Relays 300 V or 600 V	Timers
Communications	
DeviceNet direct	Modbus RTU
EtherNet/IP	Power Xpert Gateway
Modbus TCP	PROFIBUS DP
S811+ Soft Starters	
Isolation contactor	MOVs
Pump control software	Bypass starter
VFDs	
EMI/RFI	SVX/MMX/CPX
dV/dT filter 600 ft or 1000 ft	3-contactor bypass
Harmonic Correction Unit	
50 A/100 A	

3.3

Motor Control Centers

Freedom and Freedom FlashGard Check Sheets

3

Component Count Sheet

FVNR Starters		FVR Starters	
Size	Quantity	Size	Quantity
1		1	
2		2	
3		3	
4		4	
5		5	
6		6	
7			

Feeder Breakers			
Single	Quantity	Dual	Quantity
50 A		50/50	
100 A		100/50	
150 A		100/100	
225 A		150/100	
250 A		150/150	
400 A			
600 A			
800 A			
1200 A			
1600 A			
2000 A			
2500 A			
3200 A			

VFDs			
HP	Quantity	Type	
1.5		CT/VT	
2		CT/VT	
3		CT/VT	
5		CT/VT	
7.5		CT/VT	
10		CT/VT	
20		CT/VT	
25		CT/VT	
30		CT/VT	
40		CT/VT	
50		CT/VT	
60		CT/VT	
75		CT/VT	
100		CT/VT	
125		CT/VT	
150		CT/VT	
200		CT/VT	
250		CT/VT	
300		CT/VT	
400		CT/VT	
500		CT/VT	
600		CT/VT	
700		CT/VT	

Two Speed, One Winding		Two Speed, Two Winding	
Size	Quantity	Size	Quantity
1		1	
2		2	
3		3	
4		4	

Fusible Feeders			
Single	Quantity	Dual	Quantity
30 A		30/30	
60 A		60/60	
100 A			
200 A			
400 A			
600 A			
800 A			
1200 A			

Starter Circuit Protection		Future Space	
		Size	Quantity
HMCP	Thermal Magnetic	2X	
HMCPE		3X	
Fusible		4X	

Relay Panels	
Size	Quantity
2X	
3X	
4X	
5X	
6X	
7X	
8X	
9X	
10X	
11X	
12X	

Component Count Sheet, continued

Soft Starters

HP	Quantity	Duty	Cable Exit
20		Std/severe	
40		Std/severe	
60		Std/severe	
75		Std/severe	
125		Std/severe	
200		Std/severe	
300		Std/severe	Top/bottom
350		Std/severe	Top/bottom
450		Std/severe	Top/bottom
500		Std/severe	Top/bottom
600		Std/severe	Top/bottom
700		Std/severe	Top/bottom

Transformers

Single-Phase	Quantity	Three-Phase	Quantity
3 kVA		9 kVA	
5 kVA		15 kVA	
7.5 kVA		25 kVA	
10 kVA		30 kVA	
15 kVA		45 kVA	
20 kVA			
25 kVA			
30 kVA			
45 kVA			

3.4

Motor Control Centers

Freedom Arc-Resistant MCC Check Sheets

3

Freedom Arc-Resistant MCC



Contents

Description

Freedom Arc-Resistant MCC Check Sheets

Motor Control Center Takeoff Check Sheet

Customer/Job Name	Neg No.
MCC Model	
Freedom Arc-Resistant	
Service 60 Hz	208 V/230 V/ 480 V /575 V
Service 50 Hz	380 V/415 V
Three-wire /four-wire	
Structure Configuration	
42-inch front mount back-to-back	21-inch front mount
NEMA 1A /2DP	
Enclosure Modifications	
Space heaters (150 W) 120 V/240 V	
Channel sills	CBC/IBC seismic qualified
Thermostat	Split proof
Bottom plates	Split rear cover
Corner structure	Vertical section barrier
8-inch vertical wireway	Special paint color (adder)
	ABS Certification
Handle extensions ("two meter rule")	

Bus Rating and Options	
Horizontal bus	800 /1200/1600/2000/2500
Bus plating	Silver (AG)/ tin (SN)
Bus temp rise	50 °C/ 65 °C
Insulated horizontal bus	
Vertical bus	600/800/1200
Ground bus	300/600/800
Location	Top /bottom
Vertical ground bus	Lugs: incoming /each end
Neutral bus (4W only)	Half/full/ lug pad
Bus bracing	65K
Vertical bus barrier	Labyrinth with shutter
Incoming Line Metering	
IQ 130/140/150	
IQ 250/260	
IQ DP-4130	
IQ Analyzer	
Power Xpert 2250/2260/2270	
Power Xpert 4000/6000/8000	
Incoming Protection	
SPD Series surge protective device	
Incoming Line	
Breaker	
Cable—top/bottom	
Main trip: LS/LSI/LSG/LSIG/other	
Crimp lugs	Screw type lugs
Main tie main (MTM)	Auto throw over
Kirk key	Service entrance (SUSE)

MCC Spec Review Checklist, continued

Breaker Options	
Aux. contacts (1NO 1NC) (2NO 2NC)	
LS/LSI/LSIG/LSG trip units	
Under voltage release	Shunt trip
Panelboards	
14/18/26/30/32/42 count	1-pole/2-pole/3-pole
Starter Disconnect Type	
HMCP/TM. bkr.	
NEMA wiring class	
1A/1B/2B/1C/2C/1S/2S	
If any type "C" choose MTB location: Master terminal blocks (MTBs) top/bottom/relay structure	
Terminal Blocks	
Side latch pull apart (Std) (2x7-point)	
Spare points = _____% (call DSE)	Front utility (call DSE)
Nameplates: Black with White Letters / White with Black Letters	
Starter OL Types	
Bimetallic (C306)	Advanced solid-state (C441)
Solid-state (C440)	
Plug-In Starter Bucket Unit Features	
# 16 MTW wire	Coil surge suppression
# 14 SIS wire	Blown fuse indicators
# 14 MTW	Ground fault relays
Wiremarkers each end	
Ring wire lugs control	Riley current sensor
Spade wire lugs	Heater packs
Ring power wire lugs	
Wiring diagram on door	
SIS power wire	Vacuum contactors

Control Power	
Size 1 100 VA (Std)/150 VA max.	
Size 2 100 VA (Std)/150 VA max.	
Size 3 150 VA (Std)/250 VA max.	
Size 4 150 VA (Std)/250 VA max.	
Size 5 250 VA (Std)/300 VA max.	
Separate source power	
Auxiliary Starter Contacts	
NO 1/2/3/4	NC 1/2/3/4
Control Devices	
Pushbutton 1 unit/2 unit/reset	VoltageVision
Selector switch 2pos/3pos/4pos	Motorguard
Light—Std Xfmr/PTT/LED bulb	Motor load block
On/off run/stop	
Mini ETM	Panel ETM
AMM (mini/panel)	VM (mini/panel)
Riley transducer (Loop/Self Pwr)	
CTs for remote metering	
Ground fault	
IP relay—size 1/2/3/4/5/6	Voltage
Relays 300 V or 600 V	Timers
Communications	
DeviceNet direct	Modbus RTU
EtherNet/IP	Power Xpert Gateway
Modbus TCP	PROFIBUS DP
S811+ Soft Starters	
Isolation contactor	MOVs
Pump control software	Bypass starter
VFDs	SVX/MMX/CPX
EMI/RFI	
dV/dT filter 600 ft or 1000 ft	3-contactor bypass
Harmonic Correction Unit	
50 A/100 A	

3.4

Motor Control Centers

Freedom Arc-Resistant MCC Check Sheets

3

Component Count Sheet

FVNR Starters		FVR Starters	
Size	Quantity	Size	Quantity
1		1	
2		2	
3		3	
4		4	
5		5	

Feeder Breakers			
Single	Quantity	Dual	Quantity
50 A		50/50	
100 A		100/50	
150 A		100/100	
225 A		150/100	
250 A		150/150	
400 A			
600 A			
800 A			
1200 A			
1600 A			
2000 A			
2500 A			

VFDs		
HP	Quantity	Type
1.5		CT/VT
2		CT/VT
3		CT/VT
5		CT/VT
7.5		CT/VT
10		CT/VT
20		CT/VT
25		CT/VT
30		CT/VT
40		CT/VT
50		CT/VT
60		CT/VT
75		CT/VT
100		CT/VT
125		CT/VT
150		CT/VT
200		CT/VT

Two Speed, One Winding		Two Speed, Two Winding	
Size	Quantity	Size	Quantity
1		1	
2		2	
3		3	
4		4	

Starter Circuit Protection		Future Space	
		Size	Quantity
HMCP	Thermal Magnetic	2X	
HMCP		3X	
		4X	

Relay Panels	
Size	Quantity
2X	
3X	
4X	
5X	
6X	
7X	
8X	
9X	
10X	
11X	
12X	

Component Count Sheet, continued

Soft Starters

HP	Quantity	Duty	Cable Exit
20		Std/severe	
40		Std/severe	
60		Std/severe	
75		Std/severe	
125		Std/severe	
200		Std/severe	

Transformers

Single-Phase	Quantity	Three-Phase	Quantity
3 kVA		9 kVA	
5 kVA		15 kVA	
7.5 kVA		25 kVA	
10 kVA		30 kVA	
15 kVA		45 kVA	
20 kVA			
25 kVA			
30 kVA			
45 kVA			